

Peeler/ Scrubber/ Washer – 2940

Wash and Peel Small Diameter Products
Efficiently and Fast



Vanmark's Peeler/Scrubber/Washers integrate product washing and peeling into one machine effectively and efficiently. The 2940 model is available with 11 or 14 rolls and is specifically designed for products with diameters of .25-1.5". Product is tumbled through a configurable combination of thin 3" diameter rollers, speed and settings – ensuring thorough cleaning and/or peeling. Spray bars and optional reversing roll quickly remove peel waste and debris to increase efficiency. The exit gate is easily adjusted to varying product heights and product flow.

- Clean and peel small diameter product efficiently and effectively in one machine
- Configure roll types, number of rolls, speed and discharge gates to your exact operation
- Further specialize with options including: reversing roll, spray bars, drain pans, discharge gate and tumbling unit that continuously moves odd-shaped products
- Sanitary design with quick roll change system, easy access peel chamber and stainless steel drive case allows for quick and thorough cleaning

Common Food Applications

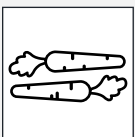

Carrots



Tree Nuts

Peeler/Scrubber/Washer – 2940

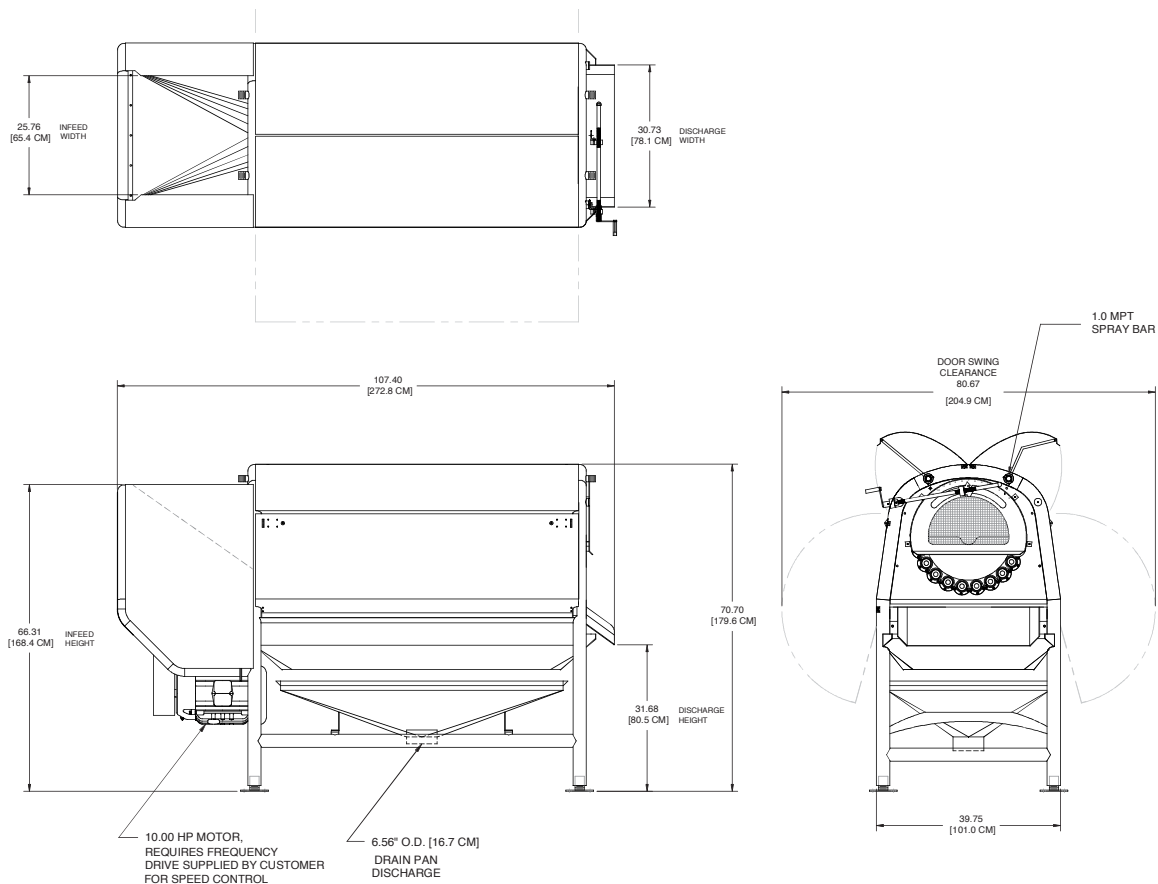

Specifications

Roll Speed: 200-700 RPM

Motor: 10 HP, 230-460 VAC, 3 Phase

Weight: 2500 lbs. (1134 kg)

Features

- Available with 11 or 14 rolls
- Available roll types: rubber finger (knocker), rubber pintle, brushes and coated abrasive
- Variable speed control requires a customer-supplied inverter or Vanmark-provided inverter at an additional cost
- Includes trapped key door interlock system (24V or 120V)

Options

- Reversing roll, auger discharge, drain pans, intermediate mid-gates, tumbling unit

E 8.17v4

Contact Us

Vanmark is proud to provide top quality equipment, exceptional service and peace of mind worldwide for the potato and produce processing industries. Contact us for more information and to custom-fit the Peeler/Scrubber/Washer – 2940 for your specific application.



To feed our growing world - Together

Phone: +1 740-201-0004

Email: sales@vanmark.com

vanmark.com