

Peeler/ Scrubber/ Washer – 2420

Wash and Peel Products Efficiently
for Smaller Capacities



Vanmark's Peeler/Scrubber/Washers integrate product washing and peeling into one machine effectively and efficiently. The 2420 model offers high quality performance and durability, with a more moderate capacity. Product is tumbled through a configurable combination of roller types, spray bars and other optional features, speed and settings – ensuring thorough and efficient cleaning and/or peeling. Its EasyFlow™ Gate has a screened chute that allows better load visibility and sanitation, while maintaining proper load control.

- Clean and peel product efficiently and effectively in one machine
- Flow rates up to 6000 pounds per hour of storage potato capacity
- Configure roll types, speed and discharge gates to your exact operation. Further specialize with options including small product package for products under 1" diameter
- Included inverter control allows for fast start up – just plug in and drive
- EasyFlow™ Gate with screened chute and manual adjustable lever for easy operation and better load visibility
- Sanitary design with quick roll change system and easy access peel chamber allows for quick and thorough cleaning

Common Food Applications

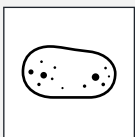

Potatoes

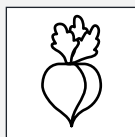

Beets

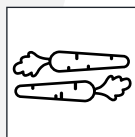

Carrots

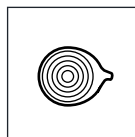

Onions

Peeler/Scrubber/Washer – 2420

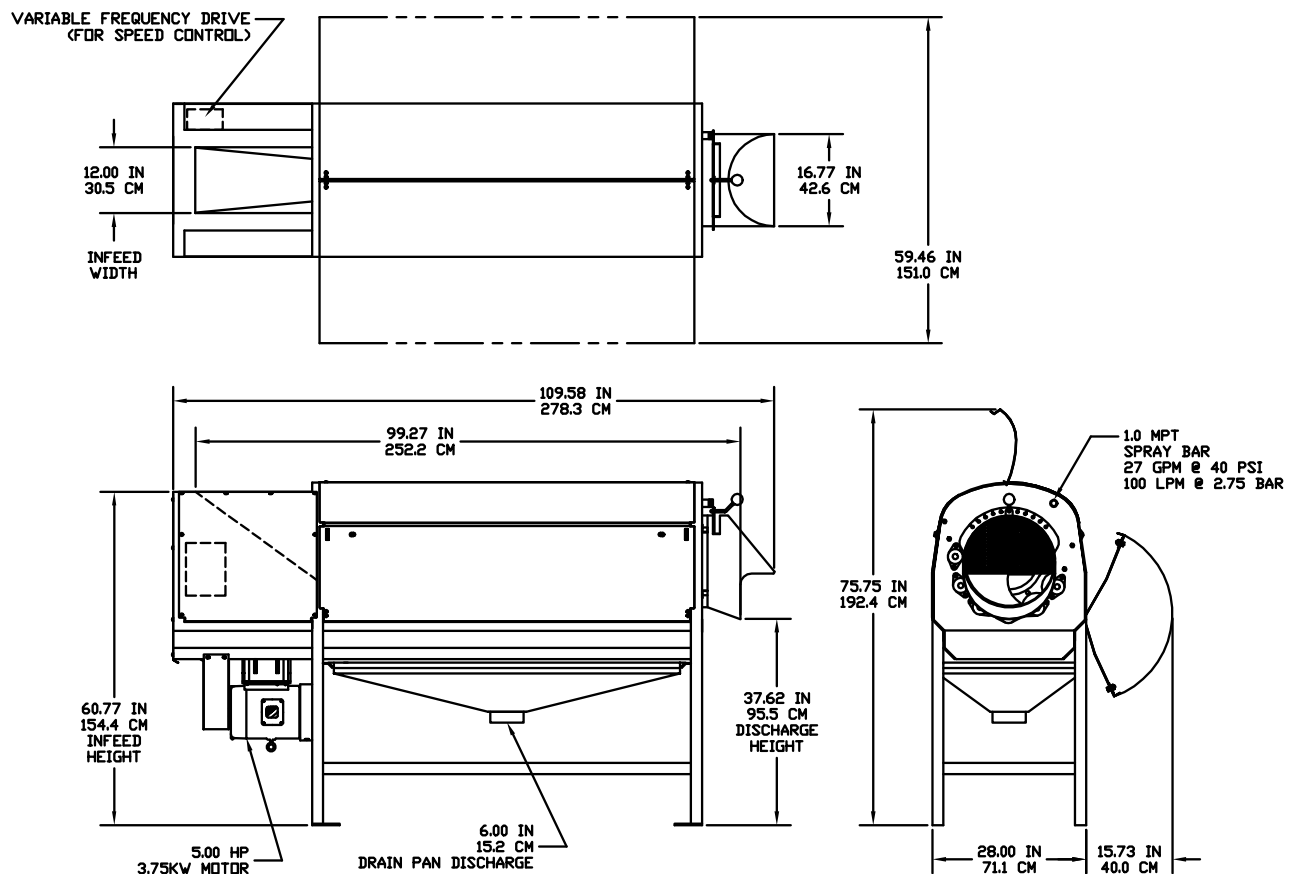

Specifications

Roll Speed: 100-550 RPM

Motor: 5 HP, 230-460 VAC, 3 Phase

Weight: 1500 lbs. (680 kg)

Features

- Available with four or six rolls
- Available roll types: rubber finger (knocker), rubber pintle, brushes and coated abrasive
- Batch gate operation
- Built-in inverter
- Includes trapped key door interlock system (24V or 120V)

Options

- Reversing roll, drain pans, small product package, one-touch inverter control with lockable power switch

E 8.17v4

Contact Us

Vanmark is proud to provide top quality equipment, exceptional service and peace of mind worldwide for the potato and produce processing industries. Contact us for more information and to custom-fit the Peeler/Scrubber/Washer – 2420 for your specific application.



To feed our growing world - Together

Phone: +1 740-201-0004

Email: sales@vanmark.com

vanmark.com