



Potato & Produce Processing Equipment

Technical Equipment Manual

Peeler/Scrubber/Washer 2920/2922 Model



To feed our growing world - Together



EU DECLARATION OF INCORPORATION FOR PARTLY COMPLETED MACHINERY

In accordance with the EC machine directive 2006/42/EC of 17. May 2006, Annex II B, we hereby declare that the following described partly completed machine in its conception, construction and form put by us on the market, is in conformity with all the relevant essential health and safety requirements of the EC machinery directive 2006/42/EC and **Regulation of material intended to come into contact with food (EC) 1935/2004 and EU 10/2011** as amended and the national laws and regulations adopting this directive. In case of alteration of the Partly Completed machine, not agreed upon by us, this declaration will lose its validity.

Machine Model: **2900 Series**
Machine Type: **Peeler/Scrubber/Washer**
Serial Numbers: **02920, 02922**
Year of construction: **2020 and Later**

Applicable harmonized European Standards:

- **EN 12100-2010:** Safety of Machinery - Basic concepts, general principles for design.
- **EN 1672-2:2005+A1:2009:** Food Processing Machinery – Basic concepts – Part 2 :Hygiene requirements.
- **EU 10/2011:** Food Contact Materials – Plastics and Articles intended to come into contact with food.
- **EN 13857:2008:** Safety of Machinery – Safe Distances to prevent hazard zones being reached by upper and lower limbs.
- **EN 60204-1:2006+A1: 2018:** Safety of Machinery - Electrical equipment of machines - general requirements.

<u>Manufacturer:</u>
Vanmark Equipment
300 Industrial Parkway
Creston, IA U.S.A
Postal Code : 50801
Tel : 740-201-0004
Email : Sales@vanmarkequipment.com

<i>Kyle V. Huck</i>
<u>Name:</u> Kyle Huck
<u>Position:</u> Engineering Manager, Vanmark Equipment
<i>Person appointed by the Manufacturer</i>

Grote International
Wrexham Technology Park
Wrexham UK
Postal Code : LL 13 7YP
Tel : +44 1978 362243
Email : jtruscott@grotecompany.com

<i>John Truscott</i>
<u>Name:</u> John Truscott
<u>Position:</u> EU CE Representative, Vanmark Equipment
<i>Person appointed by the Manufacturer</i>



**Declaration of Compliance with
REGULATION (EC) 1935/2004
EU Food Contact Certification**

Machine: 02920 Series

Serial Number: 02920, 02922

Manufacture Date: 2015 and later

The machine listed above has been designed, manufactured, and assembled using components that are in compliance with Regulation 1935/2004, which states that:

“Material intended to come into contact directly or indirectly with food must be sufficiently inert to preclude substances from being transferred to food in quantities large enough to endanger human health or to bring about an unacceptable change in composition of the food or a deterioration in its organoleptic properties.”

Further, plastics used in the construction of this machine which are intended to come in contact with food are in compliance with EU 10/2011, which more specifically defines the Scope, Definitions, and Test Methods for those materials. Materials are rated for food contact by their respective manufacturers. Note: This regulation does not apply to rubbers and silicones.

Kyle V. Huck

Kyle V. Huck

Engineering Manager, Vanmark Equipment

John Truscott

John Truscott

EU CE Representative, Vanmark Equipment

To feed our growing world - Together

300 Industrial Parkway, Creston, IA 50801, USA

Phone: +1 740-201-0004

vanmark.com





Vanmark Peeler/Scrubber/Washer

Machine Model: 2900 Series

Machine Type: Peeler/Scrubber/Washer

Serial Numbers: 02920, 02922

Year of construction: 2018 and later

Specifications for compliance with EU directives.

When this machine is installed, the electrical control system must ensure the drive motor/s on the machine are disabled when the peeler door/s are opened. All doors including upper and lower side doors on both sides, and the discharge end door must be closed and locked before drive motor/s can be enabled. The machines come standard with door interlock devices to verify all doors are closed prior to operation. If the user selected to remove the standard interlock devices to incorporate their own, they must be incorporated properly to ensure all doors are fully closed and secured prior to enabling any drive motor/s. Failure to do so can result in injury from abrasion or pinching/drawing-in of small appendages.

The machine has openings where product enters and exits the machine. Hazard symbols are placed near these areas as they cannot be completely covered preventing product from entering or exiting the machine removing the machine's primary function. Interconnecting equipment feeding product to the machine infeed area and collecting product from the machine discharge area shall be incorporated to prevent reaching hazards into these product openings.

To feed our growing world - Together

300 Industrial Parkway, Creston, IA 50801, USA

Phone: +1 740-201-0004

vanmark.com



Table of Contents

EQUIPMENT MODIFICATIONS	xi
DISCLAIMER	xi
TRADEMARKS	xi
WARRANTY	xii
SAFETY	xiii
GENERAL AWARENESS	xiii
TYPE(S) AND MAGNITUDE(S) OF HAZARDOUS ENERGY	xiii
GENERAL SAFETY PRECAUTIONS	xiv
1.0 INTRODUCTION	1-1
1.1 CONTACT INFORMATION.....	1-1
1.1.1 CRESTON, IA, USA LOCATION.....	1-1
1.1.2 GLOBAL DEALERS	1-1
1.1.3 BOISE, ID, USA LOCATION	1-1
1.2 DATA SHEET	1-2
1.2.1 ROLL CONFIGURATION.....	1-3
1.3 SPECIFICATIONS	1-4
1.4 MACHINE DESCRIPTION	1-5
2.0 RECEIVING AND POSITIONING	2-1
2.1 UTILITY CONNECTIONS.....	2-3
2.2 TRAPPED KEY SAFETY SYSTEM	2-5
2.2.1 SYSTEM OVERVIEW AND GENERAL OPERATION.....	2-5
2.2.2 SAFETY KEYS	2-5
2.2.3 SOLENOID RELEASE UNIT (SRU)	2-6
2.2.4 KEY EXCHANGE UNIT	2-7
2.2.5 DOOR LOCKS	2-7
2.2.6 SAFETY LOGIC.....	2-8
2.2.7 TRAPPED KEY WIRING SCHEMATIC.....	2-9
3.0 START UP AND SHUTDOWN	3-1
3.1 FIRST-TIME START-UP	3-1
3.2 START-UP	3-2
3.3 ADJUSTMENTS	3-3
3.3.1 DISCHARGE GATE ADJUSTMENT	3-5

3.3.2	DISCHARGE GATE AND DOOR REMOVAL.....	3-5
3.4	SHUT-DOWN	3-6
4.0	PREVENTATIVE & ROUTINE MAINTENANCE.....	4-1
4.1	DAILY:.....	4-1
4.2	WEEKLY:	4-1
4.3	MONTHLY:.....	4-1
4.4	SANITATION	4-2
4.4.1	DAILY RECOMMENDATIONS:	4-2
4.5	TROUBLESHOOTING.....	4-3
4.6	PEELING CHAMBER AND ROLLERS	4-5
4.6.1	PEELING ROLLER REMOVAL	4-5
4.6.2	IDENTIFYING PEELING ROLLERS	4-6
4.6.3	REMOVING PEELING ROLLER	4-6
4.6.4	REASSEMBLY OF PEELING ROLLERS	4-7
4.6.5	LOCK NUT ASSEMBLY INSTRUCTIONS.....	4-9
4.6.6	ABRASIVE (GRIT) ROLLERS.....	4-10
4.6.7	SINEWAVE ABRASIVE SEGMENTS	4-12
4.6.8	TIMING THE DRIVE ROLLERS (SINE WAVE ONLY).....	4-14
4.6.9	BRUSH ROLLERS	4-15
4.6.10	TWO PIECE BRUSH ASSEMBLY	4-17
4.6.11	PINTLE ROLLERS:	4-20
4.7	BELT DRIVE.....	4-21
4.7.1	DRIVE BELT REPLACEMENT	4-22
4.7.2	PULLEYS AND PULLEY HUB BUSHINGS.....	4-23
4.8	MECHANICAL ROLLER DRIVE CASE.....	4-24
4.8.1	DRIVE CASE REMOVAL AND INSTALLATION.....	4-24
4.8.2	DRIVE SHAFT AND ROLL SHAFT REPLACEMENT.....	4-25
4.8.3	ROLLER DRIVE COUPLING (ALUMINUM).....	4-25
4.8.4	ROLLER DRIVE COUPLING (QUICK CHANGE).....	4-27
5.0	PARTS.....	5-1
5.1	02920 (IMPERIAL) PART IDENTIFICATION	5-2
5.2	02922 (IMPERIAL) PART IDENTIFICATION	5-3
5.3	02920 (METRIC) PART IDENTIFICATION	5-5

5.4	02922 (METRIC) PART IDENTIFICATION	5-6
5.5	PEELING ROLLS	5-8
5.5.1	02920 PEELER ROLLS	5-8
5.5.2	02922 PEELER ROLLS	5-11
5.5.3	COMMON BRUSH PART NUMBERS	5-13
5.6	DRIVE CASE (IMPERIAL PARTS, STANDARD)	5-14
5.7	DRIVE CASE (METRIC PARTS)	5-16
6.0	EQUIPMENT OPTIONS	6-1
6.1	AUTOMATIC LUBRICATION	6-1
6.1.1	START-UP:	6-1
6.1.2	OPERATION:	6-2
6.1.3	MAINTENANCE:	6-5
6.1.4	TROUBLESHOOTING	6-6
6.1.5	AUTO LUBE PARTS LIST	6-7
6.2	DISCHARGE OPTIONS	6-9
6.2.1	NATURAL FLOW GATE DISCHARGE (IMPERIAL)	6-9
6.2.2	NATURAL FLOW GATE DISCHARGE (METRIC)	6-10
6.2.3	HANDLE ASSEMBLY, NATURAL FLOW GATE	6-11
6.2.4	MECHANICAL AUGER DISCHARGE (Standard before 10/2021)	6-12
6.2.5	MECHANICAL AUGER DISCHARGE W/ PILOT (Standard after 10/2021)	6-13
6.3	TUMBLING UNIT ASSEMBLY (02920)	6-14
6.4	TUMBLING UNIT ASSEMBLY (02922)	6-15
6.5	REVERSING ROLLS	6-16
6.5.1	REVERSING ROLLS INSTALLATION	6-16
6.5.2	REVERSING ROLL PARTS OVERVIEW	6-17
6.6	PAN SPRAY ASSEMBLY	6-18
6.7	UPPER CIP SYSTEM	6-19
6.8	AUTOMATED CIP SYSTEM	Error! Bookmark not defined.
6.8.1	LOWER CIP	6-21
6.8.2	CONTROL SYSTEM	6-22
6.8.3	UTILITY CONNECTIONS	6-23
6.8.4	TROUBLESHOOTING	6-24
6.8.5	LOWER CIP PARTS LIST	6-25

- 7.0 SPARE PARTS (SUGGESTED)7-1**
 - 7.1 02920 SPARE PARTS7-1
 - 7.2 02922 SPARE PARTS7-2
- 8.0 CHARTS & SCHEMATICS8-1**
 - 8.1 PEELING ROLL CONFIGURATION8-1
 - 8.2 TERMINAL BLOCK ENCLOSURE8-2
 - 8.3 PEELER P&ID (WITH OPTIONS SHOWN)8-3
 - 8.4 RECOMMENDED WATER SCHEMATIC8-4
 - 8.5 TRAPPED KEY SOLENOID RELEASE WIRING8-5
 - 8.5.1 24VDC WIRING SCHEMATIC8-5
 - 8.6 LINCOLN AUTOMATIC LUBE WIRING SCHEMATIC8-6
 - 8.6.1 24VDC WIRING SCHEMATIC8-6
 - 8.6.2 120VAC WIRING SCHEMATIC8-7
 - 8.7 DRIVE MOTOR Hz TO RPM CONVERSION8-8
- 9.0 COMPONENT CUT SHEETS9-1**

EQUIPMENT MODIFICATIONS

To comply with OSHA safety requirements and standards, modifications or additions which affect the capacity or safe operation of the equipment are prohibited except where the below requirements have been met:

- Manufacturer review and approval
- The manufacturer approves the modification/additions in writing
- Procedures and instruction manuals are modified as necessary to agree with the modification/additions
- The original safety factor of the equipment is not reduced

Any changes or modifications not expressly approved by VANMARK EQUIPMENT, LLC may void the user's warranty and manufacturer's liability of this system/equipment.

DISCLAIMER

The equipment described herein has been designed to comply with OSHA safety requirements and standards however, this equipment can cause bodily harm if operated in an improper manner. Do not attempt to operate this machine without first installing it correctly. The user is responsible for the proper operation of the machine and for following proper safety standards when operating it.

No warranty or representation, either expressed or implied, is made with respect to the contents of this documentation, its quality or performance for a particular purpose. Information presented in this documentation has been carefully checked for reliability; however, no responsibility is assumed for inaccuracies. This document and other information from Vanmark, its subsidiaries, and authorized distributors provide product and/or system options for further investigation by users having technical expertise. Due to the variety of operating conditions and applications for these products or systems, the user, through his/her own analysis and testing, is solely responsible for making the final selection of the product and systems and assuring that all performance, safety, and warning requirements of the application are met. The products described herein, including without limitation, product features, specifications, designs, availability, and pricing are subject to change by Vanmark and its subsidiaries at any time without notice.

In the event that this manual is translated into any other language besides English and there is a discrepancy between the two versions, the English version shall prevail and Vanmark shall not be held accountable against any damage or injury resulting from a misunderstanding caused by improper translation of the manual to the local language.

TRADEMARKS

This manual as well as the equipment described in this manual contains trademarks, copyrights, and other proprietary intellectual properties of VANMARK EQUIPMENT, LLC and its affiliates. Unauthorized use, copying, modification, distribution, or disclosure of that proprietary information is subject to civil and criminal penalties under both United States and international law.

VANMARK® is a registered trademark of VANMARK EQUIPMENT, LLC

WARRANTY

For equipment warranty information, please visit <https://vanmark.com/en-us/Terms-Conditions>. If a master supply agreement or similar contract is in place, refer to the document/s for applicable terms and conditions.

SAFETY

GENERAL AWARENESS

- The safety and operation details in this manual must be read and understood by any individual before that person operates, cleans, repairs, adjusts, supervises the operation of, or uses this machine
- Permit only authorized personnel to operate, install and maintain this equipment
- Ensure environment including building, floors, and foundations are suitable for supporting and installing the equipment prior to installation.
- Ensure all safety devices and guards are properly fastened, wired, and plumbed before energizing the system
- Do not interfere with the safety features on the system
- If temporary removal of any safety features is required, turn off and lockout motors and other energy sources as well as the control system (de-energizing electrical and pneumatic components) until the required maintenance has been complete
- Read all procedures in this document before installation or maintenance of this equipment has been performed

TYPE(S) AND MAGNITUDE(S) OF HAZARDOUS ENERGY

- Type: Electrical
 - Magnitude: See applicable motor nameplates: 208VAC-575VAC, 120VAC, 24VDC
 - Hazards (include but not limited to): Shock, Arc Flash
- Type: Pneumatic
 - Magnitude: Plant supplied air pressure
 - Hazards (include but not limited to): Pressurized tubing, Noise
- Type: Kinetic (Rotating Mass)
 - Magnitude: Spinning Drive pulleys, sprockets, rolls, shafts
 - Hazards (include but not limited to): Entanglement
- Type: Hydraulic
 - Magnitude: Plant supplied water pressure
 - Hazards: Pressurized piping (if applicable ie. Spray bars)

GENERAL SAFETY PRECAUTIONS



Safety is very important and certain safety symbols are used throughout this manual as described below. Always read and obey all safety messages. These messages are not meant to cover all possible situations that may occur. Common sense, caution and care must be exercised when installing, maintaining, or operating this equipment.

This is the safety alert symbol. This symbol alerts you to hazards that can kill or injure you or others. This symbol may be paired with other symbols and explanation to assist you.

⚠ DANGER

Failure to follow safety warnings and instructions **WILL** result in death or serious injury.

⚠ WARNING

Failure to follow safety warnings and instructions **COULD** result in death or serious injury.

⚠ CAUTION

Failure to follow safety warnings and instructions could result in moderate injury and/or damage to the equipment.

NOTICE

Failure to follow instructions could result in improper use or damage to your equipment.

1.0 INTRODUCTION

Vanmark Equipment provides customer service for this equipment through our Creston, IA USA location.

Support Includes:

- Telephone/Email support for all Vanmark Equipment
- Prompt delivery on parts orders
- On-site service calls by our field service team or global dealers

1.1 CONTACT INFORMATION

1.1.1 CRESTON, IA, USA LOCATION

- Phone: +1 740-201-0004
- Fax: +1 641-782-9209
- E-mail: sales@vanmark.com
- General Request Location

1.1.2 GLOBAL DEALERS

- List of Global Dealers
- If uncertain of who the dealer is in your area, please contact us

1.1.3 BOISE, ID, USA LOCATION

- Phone: +1 208-362-5588
- Fax: +1 208-362-3171

1.2 DATA SHEET

Purchaser Name _____
 Address _____

Model No/Serial No: _____
 Date SHIP DATE _____

NOTICE

Please refer to this information when using your manual. Any communication to Vanmark Equipment for parts and service; use the model and serial number above.
 Item numbers below (ie. ITEM #21, ITEM #7) refer to the parts pages in Section 5.0.

BASE MACHINE:	Choose a Base Machine		
IMPERIAL OR METRIC:	Choose Imperial or Metric		
DRAIN PAN (ITEM #9):	Choose a Drain Pan		
DRIVE MOTOR (ITEM #21):	Choose a Drive Motor		
PIVOT PLATE (ITEM #7):	Choose pivot plate.		
DRIVEN SPROCKET (ITEM #16):	Choose driven sprkt.		
BELT COVER (ITEM #18):	Choose belt cover.		
DRIVE BUSHING (ITEM #19):	Choose drive bushing.		
DRIVE SPROCKET (ITEM #20):	Choose drive sprkt.		
DISCHARGE:	Choose a Discharge		
AUGER GEARMOTOR (SEE 6.2.4):	Choose a Gearmotor		
REDUCER/MOTOR (SEE 6.2.5):	Choose a Reducer.	Choose a Motor.	
TRAPPED KEY:	Choose an item.	MASTER KEY CODE:	KEY CODE
LUBE SELECTION:	Choose an lube style		
TUMBLING UNIT:	Tumbling Unit		
TUMBLING GEARMOTOR	Choose a Gearmotor		
FIXED PAN SPRAY:	Choose a Pan Spray		
AUTO CIP:	Choose an item.		
UPPER CIP:	Choose a CIP		
SPRAY BAR SOLENOID VALVE:	Choose a Solenoid Valve.		
INLET CHUTE GRILL	<input type="checkbox"/>	CHUTE LINER SELECTION	<input type="checkbox"/>
FLOW METER SELECTION	<input type="checkbox"/>	REVERSING ROLLS	<input type="checkbox"/>

1.2.1 ROLL CONFIGURATION

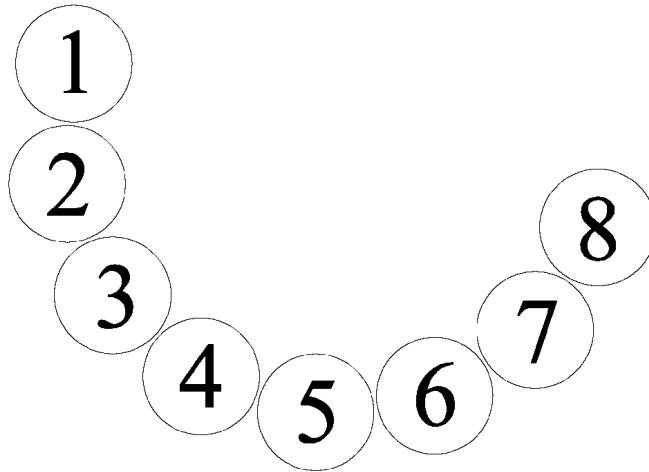

VIEWED FROM DISCHARGE END

FACTORY CONFIGURATION:

ROLL 1: Choose an item.

Choose an item.

ROLL 2: Choose an item.

Choose an item.

ROLL 3: Choose an item.

Choose an item.

ROLL 4: Choose an item.

Choose an item.

ROLL 5: Choose an item.

Choose an item.

ROLL 6: Choose an item.

Choose an item.

ROLL 7: Choose an item.

Choose an item.

ROLL 8: Choose an item.

Choose an item.

NOTES: IN A 6-ROLL CONFIGURATION, ROLLS 1 AND 8 WILL BE EMPTY

ROLL LENGTH (INCHES)	ROLL LENGTH (CM)
02922: 97.75	02922: 248.3
02920: 69.75	02920: 177.2
02920/02922, MID-LENGTH ROLL: 34.75 *REQUIRES ADDITIONAL ROLL SEGMENTS TO MAKE A COMPLETE ROLL	02920/02922, MID-LENGTH ROLL: 88.3 *REQUIRES ADDITIONAL ROLL SEGMENTS TO MAKE A COMPLETE ROLL

1.3 SPECIFICATIONS

Machine Properties		
	02920	02922
Equipment Weight lbs. (kg):	2500 (1134)	3000 (1361)
Overall Length in. (mm):	120.0 (305)	148.0 (376)
Overall Width in. (mm):	40.0 (102)	
Overall Height in. (mm):	71.0 (180)	
Motor HP (KW):	10.0 (7.5)	15.0 (11.2)
Roll Speed:	250 – 500 RPM	
Spray Bar Water Flow	1.00" (Nominal) NP	

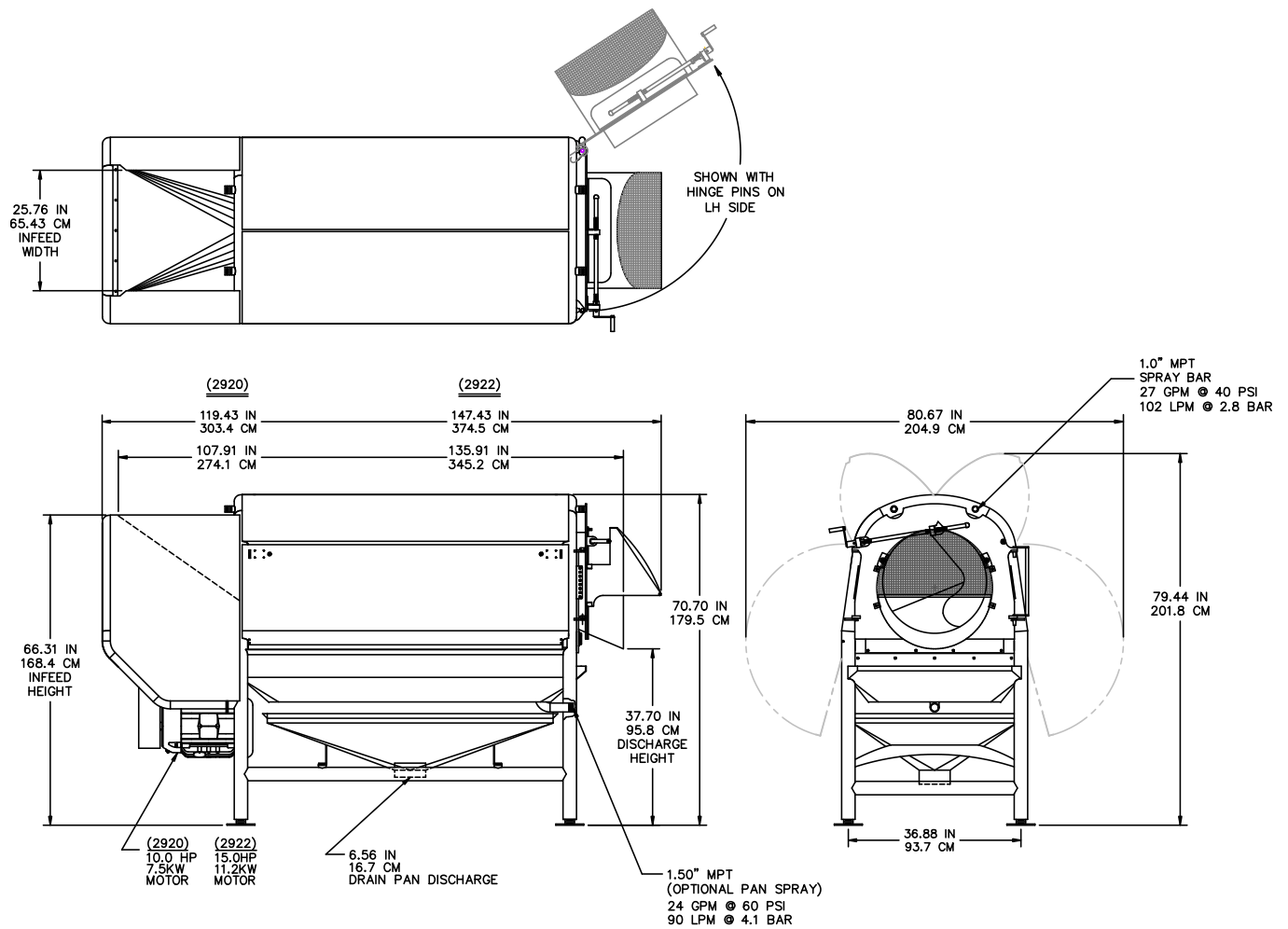

To feed our growing world - Together

300 Industrial Parkway, Creston, IA 50801, USA

Phone: +1 740-201-0004

vanmark.com

02920 / 02922 PEELER MANUAL

REV. A 2020

1.4 MACHINE DESCRIPTION

Vanmark's Peeler/Scrubber/Washers integrate the washing and peeling of a variety of products into one machine effectively and efficiently. The 2920 and 2922 models are available with six or eight rolls and are specifically designed for a large scale, around-the-clock operations. Product is tumbled through a configurable combination of rollers, speed, and settings – ensuring thorough cleaning and/or peeling. Spray bars and optional reversing roll quickly remove peel waste and debris to increase efficiency.

Vanmark's exclusive Natural Flow Gate minimizes dead spots and over-peeling – increasing yield – due to its superior product tumbling design.

The peelers are constructed of stainless steel with good hygienic design practices making them easy to clean. High quality materials and components are used ensuring long-term operation with minimal maintenance.

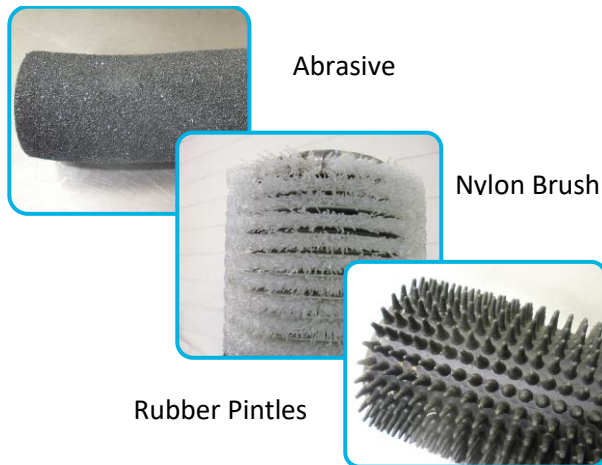

The peeling chamber consists of six (6) or eight (8) rolls with three (3) types of surface coverings. Roller types include:

- Abrasive in various grit sizes, available in Sine - Wave, straight, agitator, and lift rolls
- Nylon Brushes with varied rigidity
- Rubber Pintles in straight, or sinewave.

The sinewave double contoured rollers are designed to create a natural tumbling action for consistent peel removal. The Sine-Wave design helps prevent flat spots, even in regular shaped fruits vegetables. This means less waste and a clean finished product.

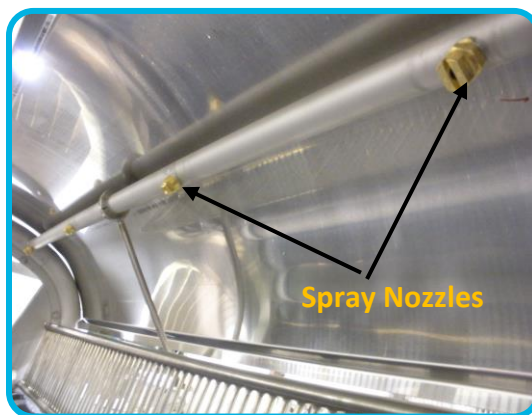

A peel chamber spray bar with nozzles along its length is located on the upper left side of the peeling chamber. This spray bar provides a constant water spray on and throughout the product as it is being processed inside the peel chamber.



The product depth in the peeling bed is controlled at the discharge end of the machine with a gate or an auger, changing the effect of the rollers on the product. The natural flow discharge gate (pictured) is manually adjustable. To increase or decrease the discharge opening, the handle is rotated until the desired position of the gate is reached. The discharge gate assembly is part of the hinged discharge door.

2.0 RECEIVING AND POSITIONING

NOTICE

RECEIPT & INSPECTION: Inspect machine for shipping damage and, if needed, make carrier claims immediately. Make sure to inspect the entire shipping skid surface for additional parts, equipment manuals, slip legs, or other loose pieces for the machine.

TRANSPORTING: Skidded machines may be moved by picking up the heavy end no more than 6" off the floor (where the machine drive motor is oriented) and sliding the skid on the opposite end to a destination. If a machine must be picked up entirely, care must be taken to not damage any part of the machine. Pick up on the skid only using a proper fork truck, pallet jack, or similar equipment designated for that purpose.

UNCRATING: Cut and discard all hold-down straps. Remove crating from around the machine. Remove machine from skids. **Remember to check the skid for any additional parts or materials such as equipment manuals or boxes, before discarding the skid.**

CAUTION

POSITIONING: Locate the machine to properly receive and discharge product. Interfacing with adjacent equipment should allow for smooth product transitions and minimal gaps to prevent product spills, prevent reaching hazards, and meet all safety requirements.

LEVELING: Unless otherwise specified, all machines are to be secured in a level position to properly function. The machine legs and frame must be plumb and level while the upper body slope can be adjusted as needed using the provided adjustment points (horizontal/level by default).

FASTENERS: All fasteners must be properly secured.

1. Inspect machine for shipping damage and make carrier claims immediately if necessary.
2. Locate the machine near its final or other desired location for un-skidding.
 - a. Machine is shipped on skid that may be towed on a level surface by the end cross member. Machine may also be carried on lift truck by extending forks under lowest horizontal tubing member of the frame. Note the center of gravity is approximately one-third of overall length from inlet end.
 - b. NOTE: If the drain pan extends below the lowest horizontal braces, it may be necessary to remove drain pan when using a lift truck.

- c. If a jib crane is used to move machine, use two (2) slings under lowest horizontal tubing of frame. Use spreaders on top of the machine to reduce sling pressure against the sides/doors of machine.
3. Remove the bolts and straps holding the machine to the skid and lift the machine off the skid.
4. Machine is to be located over a waste trench, floor drain, drainpipe, or other means to dispose of water and product waste that exits the machine drain pan. Locate machine to allow for adequate clearances to other equipment. Before final setting of the machine, verify proper access to covers, removal and/or opening of discharge door with natural flow gate or auger discharge, peeling chamber doors, product infeed and discharge openings, Auto Lube Pump (if supplied) and ventilation around the drive compartment.
5. Machine doors must be clear of all obstacles:
 - a. Two (2) peel chamber top
 - b. Two (2) peel chamber side doors
 - c. One (1) peel discharge gate
6. Fixed drive compartment panels shall remain removable, free of plumbing and conduit mounts.
7. Vanmark does not recommend drilling and tapping holes in machine frame for mounting utilities as they are hermetically sealed for good hygiene practices.
8. Machine is typically level for proper operation. Verify machine level on the bottom roller inside the machine. To make level adjustments, turn the appropriate foot pads in or out of the frame legs to adjust their height. For certain applications, the machine may have a fall of 0 – 1"/2.5cm in six (6) feet/1.83m toward discharge end. The machine cannot be sloping towards the infeed end of the machine.
9. After final position and level is determined, anchor the machine to the floor through the holes in hold down pads in the frame. If mounting the machine on stand or elevated framework, level the machine as previously described and anchor it by bolting or welding it to the stand.
10. Check that all fasteners are tight.
11. It is the responsibility of the equipment owner, user, and/or installer to ensure mating equipment is setup to adequately prevent reaching hazards through the product inlet and discharge paths and drains are connected to minimize peel residue and water on the area floor that may cause slippery conditions.

CAUTION

Keep all hands, feet, loose clothing, and foreign objects out of machine while it is operating. Always de-energize and lockout the machine when maintenance is required. Always verify door prop rods are secure before resting the door on them. Use care when closing and opening machine doors ensuring nothing may be pinched, trapped, or jammed between the door and a fixed surface.

2.1 UTILITY CONNECTIONS

- Vanmark does not supply any material or labor for utility connections.
- All electrical connections shall be permanent water-tight and shall conform to Local and National electrical codes. **Confirm all voltages prior to applying power to machine.**
- When routing cables, conduit, and water piping; do not interfere with access to machine covers and other moving and removable parts.
- There is no 3-phase junction box on the peeler so motor wiring will connect directly to the motor conduit box or to the local disconnect (available option) if present. Motor/s are to be connected to and controlled by an inverter for speed control. A 3 second ramp-up and 1-2 second ramp-down delay is recommended to limit stress on drive components and meet safety requirements for door opening. The recommended frequency range is from 20 to 90 Hz. Verify all motor rotation directions by “bumping” the motors. Refer to the diagram below for proper rotation directions. Motor and roll rotation is counterclockwise, when viewed from the discharge end of machine.
- Water supply to the spray bar connection is made at the 1.00” MPT located at top, discharge end of machine. Installation of solenoid valve connected to the main drive power and a manual valve (spherical ball type) to control and isolate water flow is recommended.
- Open the ball valve fully to flush contaminants from new piping. Check that water flow at the nozzles is even and full. If any display reduced or incomplete water flow, stop water flow and remove, clean, and re-install the nozzle if necessary. Set the ball valve position at a minimum flow setting that provides full spray coverage of the peel chamber to minimize the use of water.
- **Note: Other Utility connections may be required for optional equipment. Refer to the Data Sheet in Section 1.2 and the Options pages in Section 6.0 for specifics on your machine and connection details.**

⚠️ WARNING

Utility Requirements: See section 1.2 Data Sheet and the Schematics Section 8.0 for utility requirements. Always verify utility requirements on supplied motor nameplates and equipment approval drawings.

Electrical Connections: All connections shall be permanent, water-tight, and shall conform to National and Local electrical codes. When routing cables and conduit; do not interfere with access to machine covers, doors, product transfer areas, and other moving or removable parts. It is recommended to use flexible conduit for motor connections. Ensure all powered devices are properly controlled by local emergency stop and/or disconnect switches.

Safety: All safety protocols must be followed when making utility connections. Only properly qualified personnel can make utility connections. All connections shall be treated as potential hazards until being tested and inspected where they may be deemed “safe”. It is recommended to use non-slip flooring around the peelers to prevent slipping from water or peel residue on the floor.

PROCESS SPRAY BAR		
PRESS.	02920, (4) NOZZLES	02922, (5) NOZZLES
40 PSI	27 GPM/102 LPM	33 GPM/125 LPM
20 PSI	19 GPM/ 72 LPM	23 GPM/87 LPM
10 PSI	14 GPM/ 53 LPM	17 GPM/64 LPM
5 PSI	10 GPM/ 38 LPM	12 GPM/45 LPM
2.5 PSI	6 GPM/ 23 LPM	7 GPM/26 LPM

**UTILITY CONNECTIONS
STANDARD MACHINE (2920/2922)**

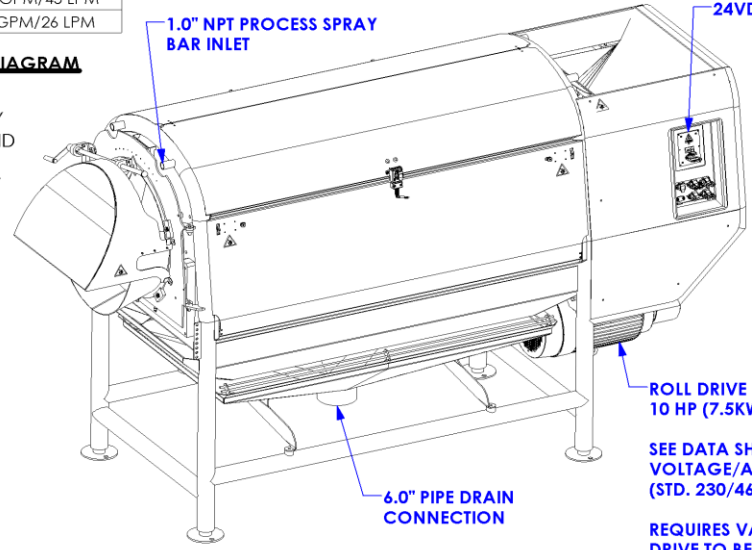

RECOMMENDED PLUMBING DIAGRAM

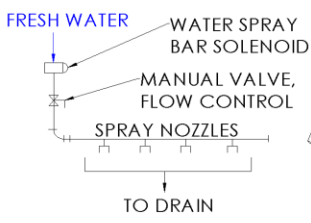

TRAPPED KEY SOLENOID
(ELECTRICAL ENCLOSURE
OTHER SIDE)
24VDC OR 120VAC

ROLL DRIVE MOTOR
10 HP (7.5KW), 3 PHASE

SEE DATA SHEET FOR
VOLTAGE/AMPS
(STD. 230/460VAC, 26/13 FLA)

REQUIRES VARIABLE FREQUENCY
DRIVE TO BE SUPPLIED BY USER
FOR SPEED CONTROL OF ROLLS

PROCESS SPRAY BAR		
PRESS.	02920, (4) NOZZLES	02922, (5) NOZZLES
40 PSI	27 GPM/102 LPM	33 GPM/125 LPM
20 PSI	19 GPM/ 72 LPM	23 GPM/87 LPM
10 PSI	14 GPM/ 53 LPM	17 GPM/64 LPM
5 PSI	10 GPM/ 38 LPM	12 GPM/45 LPM
2.5 PSI	6 GPM/ 23 LPM	7 GPM/26 LPM

**UTILITY CONNECTIONS
W/AVAILABLE OPTIONS (2920/2922)**

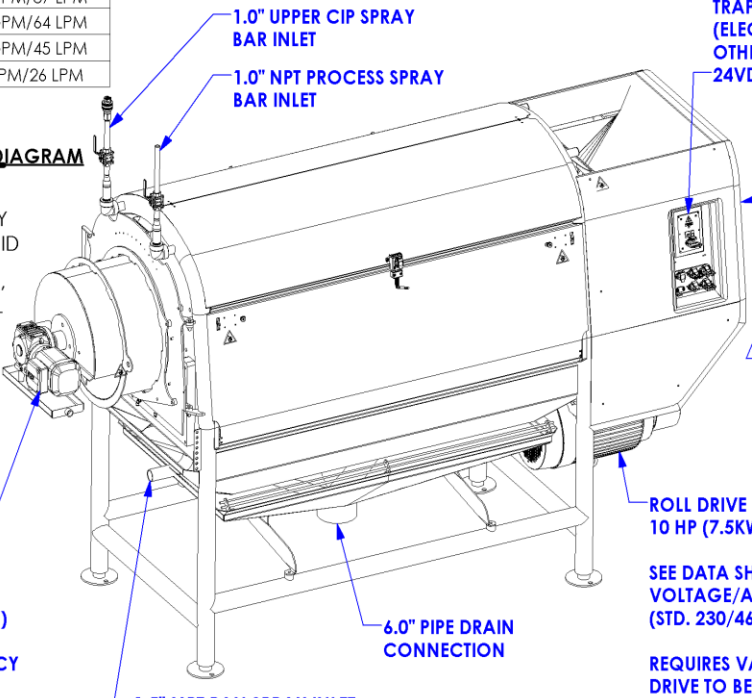

RECOMMENDED PLUMBING DIAGRAM

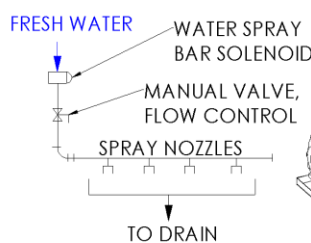

TRAPPED KEY SOLENOID
(ELECTRICAL ENCLOSURE
OTHER SIDE)
24VDC OR 120VAC

TUMBLING UNIT MTR
1.0 HP (0.75 KW)

REQUIRES VARIABLE
FREQUENCY DRIVE

AUGER DISCHARGE MOTOR
0.75 HP (0.55KW), 3 PHASE

SEE DATA SHEET FOR
VOLTAGE/AMPS
(STD. 230/460VAC, 1.8/0.9 FLA)

REQUIRES VARIABLE FREQUENCY
DRIVE TO BE SUPPLIED BY USER
FOR SPEED CONTROL OF ROLLS

ROLL DRIVE MOTOR
10 HP (7.5KW), 3 PHASE

SEE DATA SHEET FOR
VOLTAGE/AMPS
(STD. 230/460VAC, 26/13 FLA)

REQUIRES VARIABLE FREQUENCY
DRIVE TO BE SUPPLIED BY USER
FOR SPEED CONTROL OF ROLLS

To feed our growing world - Together

2.2 TRAPPED KEY SAFETY SYSTEM

2.2.1 SYSTEM OVERVIEW AND GENERAL OPERATION

The trapped key system is a safety system designed to avoid potential hazards for operators and it must be used and controlled properly. Each machine door is equipped with a door lock and the trap key system is located on the left rear side of the peeler near the drive case.

The system is controlled in tandem with the ON/OFF state of the main roll drive motor, and any other motors on the peeler (if applicable). Whenever the roll drive is ON, the keys are locked in place not accessible. Likewise, when the roll drive is OFF, the red light on the Solenoid Release Unit (SRU) will be illuminated indicating the master key is free.

1. With the machine OFF and master key free, turn the master key located in the solenoid release panel and remove it. **Note the door keys are still not accessible at this stage.**
2. Insert the master key into the key exchange in the master key slot and turn it. Now the door keys are accessible. **Note, with any door key removed from the key exchange, the master key is trapped in the key exchange.**
3. With a door key removed, it now can be used to unlock a machine door. Insert the key into the door lock and turn it. Then the lever can be turned and pulled to unlock the door.
4. When finished, close the machine door and lock it by re-inserting the lever into the lock. **Note the door key is trapped in the lock while the lever is unlocked.** Once the lock lever is adjusted to lock the door, the door key can be removed.
5. Return the door key to the key exchange and turn it into position. Once ALL door keys are returned and in place, the master key can again be removed.
6. Return the master key to the solenoid release master key slot and lock it. Now the roll drive is enabled again to run the machine and the door keys are not accessible. **Enabling the roll drive by returning the key does not and must not, start the machine.**

Safety System Purpose

- Prevent the machine from being enabled/started unless all safety conditions are met:
 - All doors are closed and locked
 - All door keys in the exchange panel
 - Master key in the Solenoid Release Unit (SRU) and locked
- Prevent opening a machine door unless the drive motor (and all other motors) have been stopped

⚠ WARNING

A “Trapped Key Delete” option is available allowing users to integrate their own safety system used in their operation. It is the user’s responsibility to properly apply this safety system to meet applicable safety requirements and achieve the safety system purpose outlined above.

2.2.2 SAFETY KEYS

Each peeler in each facility will be issued unique codes for the primary and secondary keys to prevent unlocking of one peeler using another peeler’s key. Vanmark uses alpha numeric key sets, A101 – Master key, B201 – Secondary keys; each key is uniquely machined so that only that key will work in its specific lock or switch. All door keys on one machine are the same.

2.2.3 SOLENOID RELEASE UNIT (SRU)

The SRU is wired into the facility's control system, requiring an external voltage signal to energize a solenoid to release the primary key. Removing the master key mechanically activates 2 NC & 2 NO "key position" contacts that are available for signaling to the plant control system that the machine is in a condition in which the doors could be open.

The SRU is the only portion of the Trapped Key System that requires electrical. The key exchange and all door locks are strictly mechanical components. This provides a simple system with minimal wiring and/or conduit on the machine. When the Solenoid unit is activated meaning the master key is "free", the red light on the unit should be illuminated.



2.2.4 KEY EXCHANGE UNIT

The key exchange operating principle is such that no secondary key can be removed from the unit until all master keys have been inserted, rotated, and trapped.

After the master key has been released from the SRU, it must be inserted into the key exchange and rotated which allows the secondary keys to be rotated and removed. The master key remains trapped until all secondary keys have been re-inserted, rotated, and trapped.

The secondary keys may be used to unlock the guard locks on the doors. Similar to all other steps in the process, the key is trapped in the door lock when the lock is opened. The key only becomes free to return to the key exchange after the lock is closed and locked.



2.2.5 DOOR LOCKS

The door locks are designed to prevent access to a potentially hazardous area unless the appropriate key is inserted into the lock.

The locks are configured so that the lever handle cannot be released until a key is inserted, rotated, and trapped, allowing the door to be opened.

The key cannot be removed until the latch handle is inserted back into the lock and rotated.

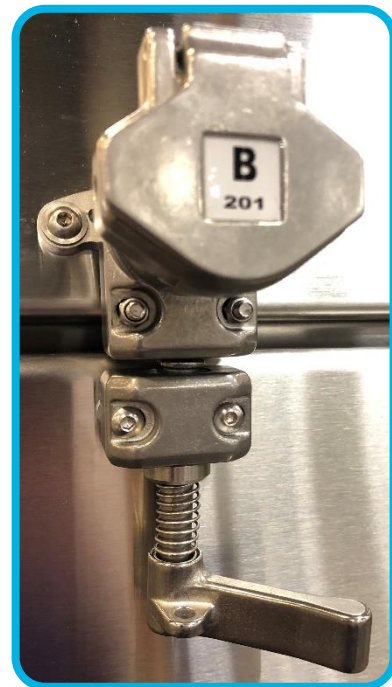

2.2.6 SAFETY LOGIC

NOTICE

Refer to Section 8.0 for wiring details for the trapped key system. Applying incorrect voltage can damage the unit and must be verified prior to applying power. Refer to the machine approval drawing, P&ID, Electrical Box on the machine, or Data Sheet in Section 1.2 for proper voltage.

Wiring of the SRU to the plant control system may differ, depending on how each plant provides external power and any signal feedback to/from their machines. The wiring scheme described here is one example of multiple connection options. It is the sole responsibility of the user to integrate the safety system properly and verify functionality with their control system. Vanmark recommends the following:

1. The plant control system remove power to all the drives on the Vanmark machine and any adjoining equipment, deeming the equipment safe to enter.
2. Then a designated voltage signal can be used to energize the solenoid release unit (to terminal 9), releasing the master key.
3. After the master key is rotated and removed, at least one of the four (4) normally closed “key position” contacts in the SRU, should be used to provide feedback to the plant controls disabling the peeler drive motor/s as long as the “key position” contact remains open.
 - **Note:** There are also qty. (2) optional contacts that change from closed to open, or open to closed as soon as power to the solenoid is applied. These contacts can be used for positive feedback that the key release is energized.
4. After service is complete, the master key is re-inserted into the SRU and rotated to actuate the “key position” contacts signaling that the machine is secure and ready to start. The external signal is then removed from the SRU before the drive motor/s can be re-energized and the machine put back in service.

2.2.7 TRAPPED KEY WIRING SCHEMATIC

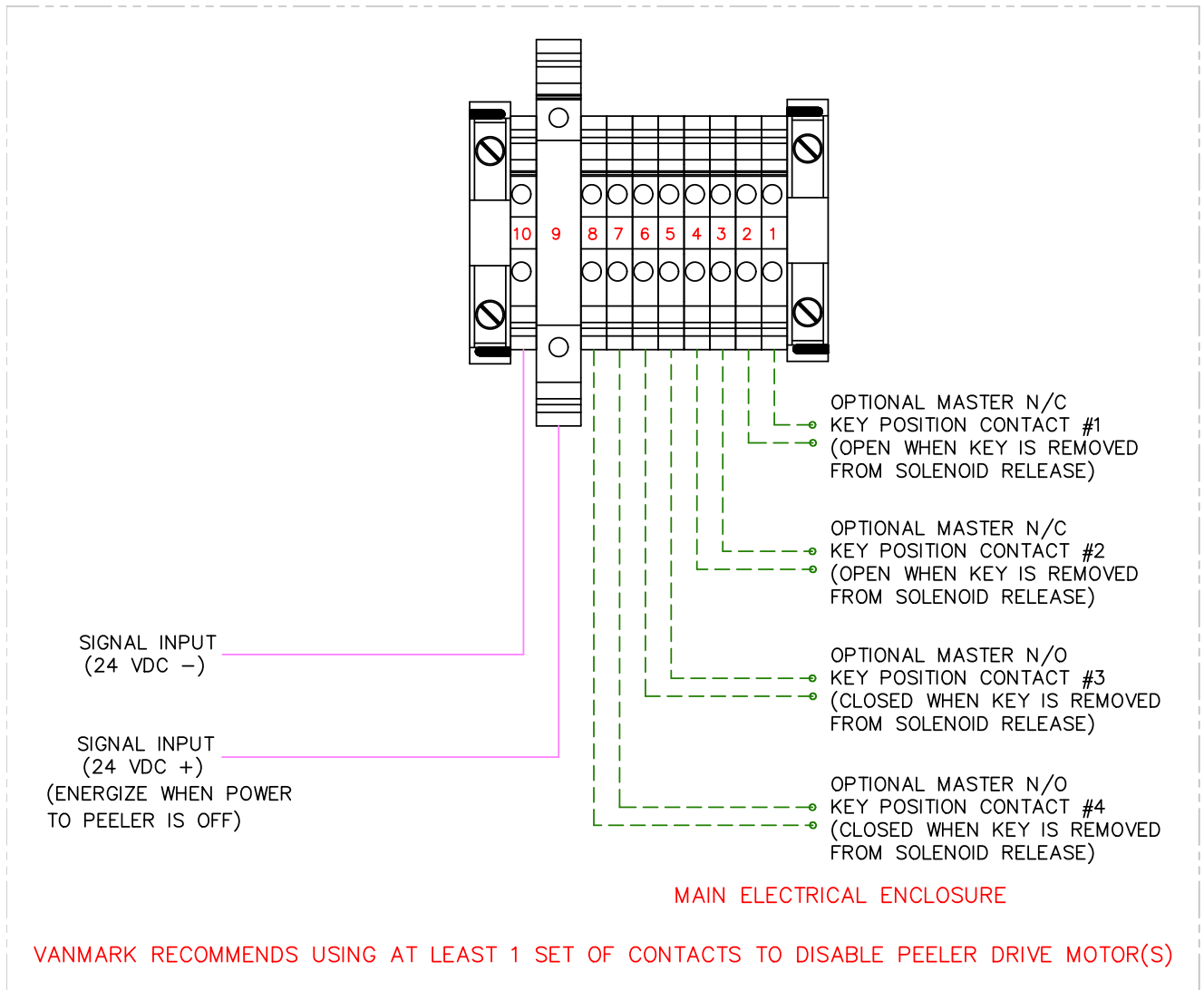

60-61067

3.0 START UP AND SHUTDOWN

3.1 FIRST-TIME START-UP

1. Lubrication – At the discharge end, check grease lines to discharge bearings; check that bearings have grease and set screws are tight (45-50 in-lbs.).
 - a. Auto lube System (if applicable) – Check that the grease pump reservoir is full, and power is available to the pump.
2. Discharge Gate – Verify that the discharge gate is set to approximately halfway open.
3. Loose Equipment - Check that all chutes or other loose items are in their proper place before powering up machine.
4. Peeling Chamber – Verify the peel chamber is clear of any loose or foreign items.
5. Covers – Close, latch, and lock all peeler doors and ensure all fixed covers are in place and secured.
6. Personnel - Verify all people are clear of machine.
7. Power-Drive System - Turn on power but do not start machine.
8. Drive System – Set motor control for the main roll drive to 250 rpm for initial startup.
 - a. Motor Rotation – “Bump” the power to the roll drive motor and check that roll rotation is the proper direction. When viewed from the discharge end of machine, the peeling rolls should turn counterclockwise. Repeat and verify rotation directions for other drives on the peeler (if applicable). See diagram below:

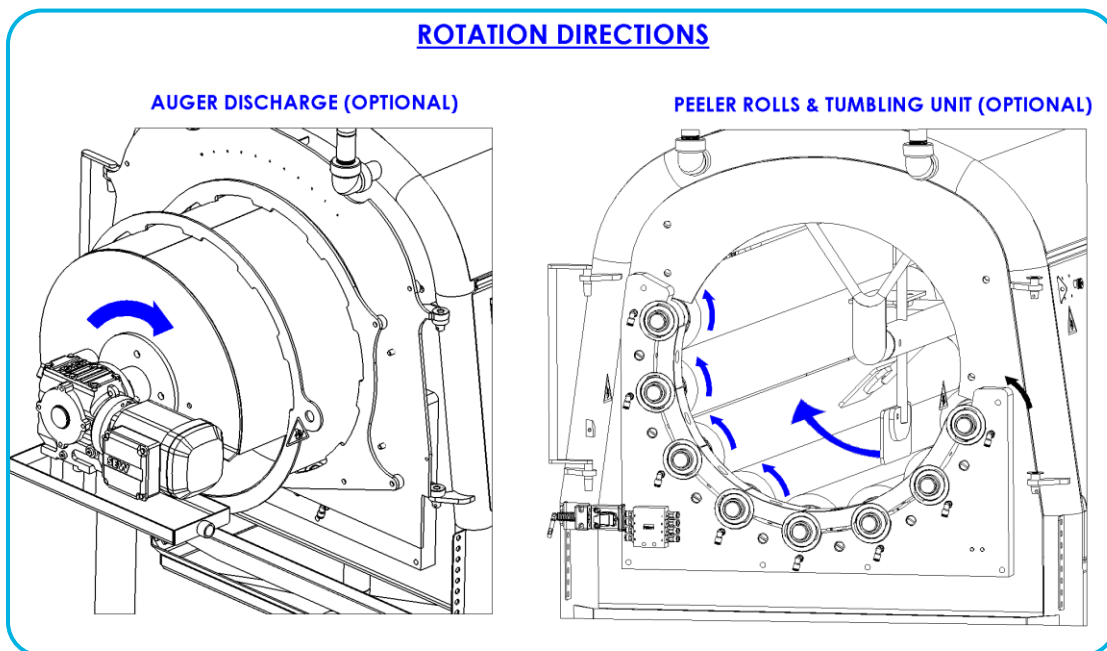

9. Water - Turn on water to spray bar at machine or ahead of solenoid valve and test water flow to spray bar.
10. Product Tests - Machine is now ready to run product and machine may be turned on:
11. Filling Bed - Allow peel chamber to fill with product (typically full until even with roll #8 centerline). For best results, product flows to machine should be kept as even as possible since fluctuating flow will fluctuate bed depth.
12. Discharge Gate - Adjust the discharge gate manually until the desired peel removal or washing performance and flow rate is achieved. See Section 3.3 for guidance on making adjustments.
13. End of Test - See Section 3.4 for shut-down sequence of operation.
14. Daily Operation - Machine is now ready for production. See Section 3.2 for start-up sequence of operation.

3.2 START-UP

1. Check all lubricant and fluid levels to be sure they are adequate. Check all bearings for proper lubrication and grease as required.
2. All parts shipped loose from base machine should be properly installed and secured and machine is ready to receive and properly handle incoming product.

WARNING

All covers and shields should be properly closed, affixed, and in place prior to start-up. Keep all hands, feet, loose clothing, and foreign objects out of machine while it is operating. Always turn off and lockout power when maintenance is required.

3. All people should be clear of any moving parts of the machine.
4. Manually close the discharge gate allowing the machine to fill with product upon initial startup.
5. Turn on necessary utilities to machine. Some (ie. Water) are manual and only turned on during production. Water may be controlled by a solenoid and a manual valve to allow fresh water supply to the system. Drives should start between the low and middle range of their speeds.

CAUTION

Keep all hands, feet, face, loose clothing, and foreign objects out of machine while it is operating. Always de-energize and lockout the machine when maintenance is required. Water/Chemical Spray may be present inside the machine when water is on.

6. Begin product flow. After the peeling chamber fills with product (approx. level with Roll #8), manually open the discharge gate to the desired position and product depth is adequate for achieving good peel removal or washing. Run product through the machine at normal flow rate. Check for product condition, proper machine function, and roll speed/flow rate targets. See Section 3.3 for making adjustments.

3.3 ADJUSTMENTS

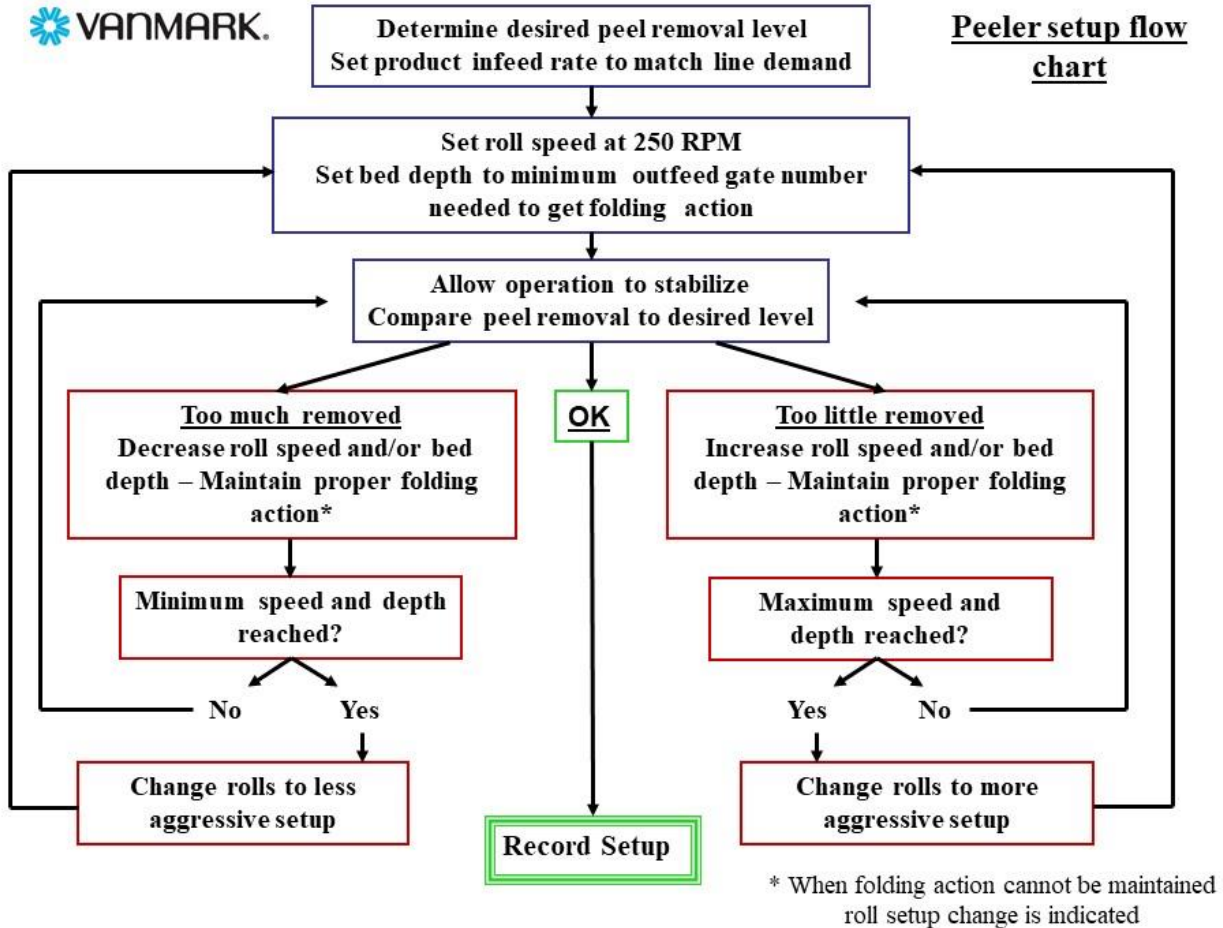

Three major factors that affect continuous peeling efficiency are:

1. Effect of roller surface on product.
2. Amount of roller surface moving past product.
3. Retention time of product in peeling chamber.

Discharge Gate Position: Discharge Gate position will control product load level and retention time. Product load level will determine how much force is applied to the product on the roll surface and will affect tumbling action.

Product Tumbling: A good tumbling action will produce a more evenly peeled product. Retention time is how long the product is in contact with the rolls inside the machine. These adjustments work hand in hand with roll speed.

Roll Speed: Roll speed is a very important factor in how well your peeler/washer performs. It is very easy to run the rolls at a higher rpm than required to achieve proper peeling/washing. Roll over speed will cause increased peel loss and product damage, and an inconsistent peel removal. After machine installation, take some time to determine proper bed depth and tumbling action with as low roll rpm as possible.

Operation: For best results, a steady inlet flow of product is necessary for consistent machine operation.

Adjustments are a judgment of the operator that is made by examining the product when it reaches the inspection table. Speed of rolls and discharge gate opening should complement each other. Different products and product condition will determine ultimate machine setup.

Remember -- too much peel removal creates excess product loss. Proper adjustment is essential for efficient operation of machine.

Roll speed on the 2920 Peeler/Washer is set with an electrical inverter. Inverter installation and operation is the responsibility of the customer given the specific nature of the application. Electrical requirements for this machine can be found in Section 1.2. To find the exact Hertz output to roll RPM, a handheld tachometer will be needed to set the roll RPM manually through the inverter. A table with approximate roll speeds is shown in Section 8.7. A local certified electrician will be needed to install and program an inverter for use by personnel.

3.3.1 DISCHARGE GATE ADJUSTMENT

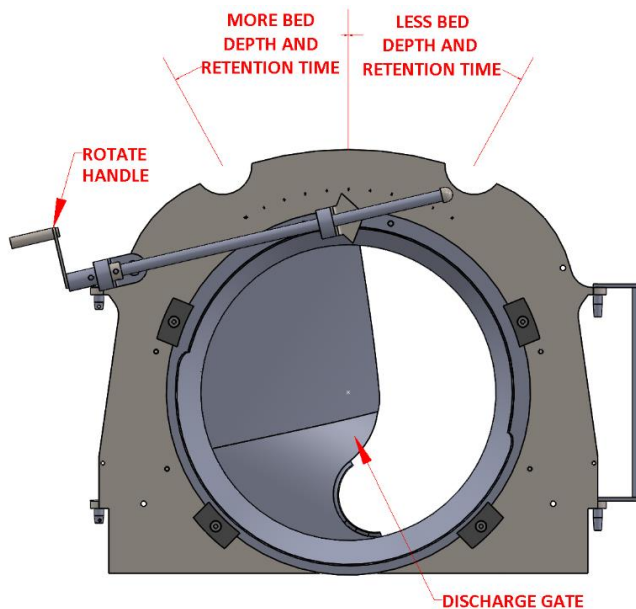

To adjust discharge opening, rotate handle to move gate to desired location.

Note: Numbers on calibration plate are for reference in daily settings, they do not give any specific product volume discharging from machine.

3.3.2 DISCHARGE GATE AND DOOR REMOVAL

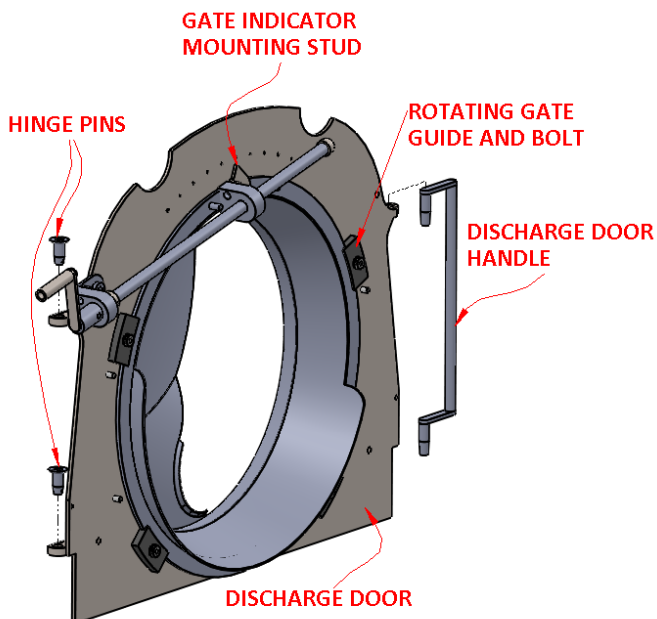

To remove gate from door, unbolt gate indicator from stud, then remove rotation guides and bolts. To remove door, raise handle and swing open door. After securing door assembly, lightly tap hinge pins out of the hinge flats and remove

3.4 SHUT-DOWN

1. Stop all product flow to the machine. If the machine is part of a processing line, it requires progressive product clearing beginning with the first machine in the process (product introduction) and working downstream.
2. Allow product to discharge from the machine until it's empty. This can be accelerated by manually opening the discharge gate.

CAUTION

Never force product through machine or manually remove product or debris unless the machine is properly de-energized and locked out.

3. If machine is outfitted with optional CIP, Pan Spray, or other cleaning system, cycle the cleaning systems with the machine rolls ON.
4. Turn OFF all drives, water supply, and other utilities and remove power
5. With extended shutdowns for maintenance, sanitation, or other activity, disconnect, de-energize, and lockout all sources of energy on the machine.

WARNING

Always use proper lockout/tagout procedures when de-energizing machine for maintenance, sanitation, or other similar process on the equipment.

6. Cleaning - Wash down peeling chamber ensuring peel residue and other process debris is rinsed from the peeling chamber, peeling rolls, and surrounding sheet metal. Reference Section 4.0 for sanitation guidelines.

NOTICE

During high pressure cleaning do not aim steam directly into drive compartment or onto bearings.

7. Grease discharge end bearings until grease is visible manually (or via manual greasing cycles on Auto Lube).
8. Covers - Close all covers and lock machine doors.
9. Clean exterior of machine - High pressure spray or a cleaning solution used with a cloth, is recommended. Reference Section 4.0 for sanitation guidelines.

NOTICE

During high pressure cleaning do not aim steam directly into drive compartment or onto bearings.

10. Loose Equipment - Check that all chutes and other loose items are in their proper place.

4.0 PREVENTATIVE & ROUTINE MAINTENANCE

Your Vanmark machine is designed and constructed for efficient operation, but it does require service and maintenance. A major breakdown can be expensive, so it is economical to follow a routine service program preventing or identifying problems prior to becoming a breakdown.

The estimated service schedule is based on eight (8) hours of production per day, five (5) days per week under normal operating conditions. Frequency may vary as production time and operating conditions change.

4.1 DAILY:

- Clean peeling chamber, peeling rolls, and all areas of machine to remove debris, disinfect, and sanitize the machine.
 - Frequency may be multiple times per day per operation schedule.
- Check condition of peeling rolls.
- Check for clogged nozzles on spray bar.
- Check for line up-time (maximum number of shut-offs not to exceed three (3) times per hour with 85 - 90% line up-time).
- Grease roller bearings at discharge end of machine with #2 food grade grease.
- For manual grease systems, grease every 8 hours, and after every sanitation routine.
- Grease bearings until grease expelled from seal is visible.
- If using auto lube systems:
 - Check auto lube reservoir for sufficient fill.
 - Inspect auto lube, grease lines, fittings, and bearing blocks for leaks.

4.2 WEEKLY:

- Check for loose or binding hardware.
- Check bearings for excessive wear.

4.3 MONTHLY:

- Check/Tighten set screws in bearings. (45-50 in.-lbs.)
- Inspect drive case bearings for excessive wear.
- Check for frayed or misaligned belts and or pulleys.
- Adjust drive belt if required.

⚠ CAUTION

Keep all hands, feet, face, loose clothing, and foreign objects out of machine while it is operating. Always turn off and lockout power when maintenance is required. Discharge End Bearings may be hot if low on grease or near end of life. Water/Chemical Spray may be present inside the machine when utilities are on, always wear appropriate PPE [Personal Protective Equipment].

4.4 SANITATION

Vanmark's equipment and parts have been designed and made of materials and workmanship that make them adequately cleanable when properly maintained. Various optional "CIP" and/or pan spray systems are available for the machine to aid with cleaning. It is at the equipment user's discretion to determine the appropriate level of sanitation required for each machine's specific application and location within a given facility. This should be done by the user to maintain compliance, and consistency with each company's own sanitation standards.

4.4.1 DAILY RECOMMENDATIONS:

- Wash down entire machine including peeling rolls, ensuring the machine is clear of residue and debris.
- High pressure spray and/or cleaning solution may be used.
- Perform any re-lubrication after clean-up.
 - If your machine is equipped with an optional Auto Lube System, press and hold the orange button on the electrical enclosure to perform a manual lube cycle

WARNING

All covers and shields should be properly closed, affixed, and in place prior to start-up. Keep all hands, feet, loose clothing, and foreign objects out of machine while it is operating. Always turn off and lockout power when maintenance or sanitation is required.

NOTICE

During high pressure washdown, **DO NOT** aim directly at bearings or electrical boxes.

4.5 TROUBLESHOOTING

SYMPTOM / PROBLEM	POSSIBLE CAUSE	SOLUTION
Poor Peel Removal	Tumbling action in peeling chamber is slow.	Increase speed – See Section 3.2 for Adjustments
	Sequence and type of roller is not effective with product	Contact Vanmark for recommendations
	Too much product in peeling chamber	Adjust discharge gate (See Adjustments Section), Maintain even infeed
	Excessive downtime	Control product flow for constant/even infeed rate
	Abrasive rollers have starch build up or are worn	Clean or replace
	Inadequate water volume	Check process spray bar for adequate water supply and clogged nozzles
	Brush rollers are worn	Replace
	Brushes installed backwards	Verify brush orientation such that off-colored stripes on the brush are located at the infeed end of the machine
	Roll setup is not effective with product	Contact Vanmark for recommendations
	Roll Rotation Direction is incorrect	See Section 3.0 for diagram on rotation directions and verify proper roll rotation
Product loss from peeling chamber	Roller surface worn	Replace
	Splash Guards improperly aligned or missing	Realign by lifting the splash guard over the roll inserting the guide pins into the end and adjust bolts on opposite end as needed
Rollers not turning	Product or foreign item jammed in bed	Turn off power to peeler, remove obstruction. Restart
	Belt Loose or Broken	Repair or Replace
Rollers run clockwise at discharge end	Drive motor rotation is counterclockwise	Change motor rotation

Troubleshooting Continued

Electric drive or tumbling motors do not run	Power is off	Turn on Power (check local disconnect, breaker, and main power)
	Wiring loose or disconnected at motor or motor starter	Check wiring
	Motor defective	Replace motor
	Breaker off or tripped	Reset breaker, turn off power to peeler/washer. Check peeler bed, tumbler, drive case, belts, etc. for obstruction that may have caused breaker to trip. Reset breaker, turn on peeler. If breaker continues to trip, check for proper breaker size, based on motor amp draw.
No water to spray bar	Manual valve closed	Open valve
	Nozzles on spray bar clogged	Clean nozzles
	Solenoid defective or incorrectly wired	Replace Solenoid
	Drive motor is off	Turn on motor to activate water solenoid (control setup may vary for water solenoid)

****Note:** Some Troubleshooting information for machine options are described in the options pages. See Section 6.0 for equipment options.

⚠ DANGER

Keep all hands, feet, loose clothing, and foreign objects out of machine while it is operating. Always turn **OFF** power and lockout machine when maintenance is required. All covers and shields should be properly closed, affixed, and in place prior to start-up. Only qualified personnel should perform maintenance tasks.

4.6 PEELING CHAMBER AND ROLLERS

4.6.1 PEELING ROLLER REMOVAL

Roller removal is required to change roll arrangement, replace rolls or shafts, or to service certain items in the drive compartment such as drive coupling replacement, belts, shafts, or bearings. To work on roller related drive components with rollers still in machine is nearly impossible.

Roll Removal - First, remove power and lockout the peeler to ensure it is disabled before performing service or activate the trap key door locks by removing the master key which must disable all drives on the machine. Access the peeling rolls by unlocking the trap key door locks and opening the peel chamber side covers and the discharge door to their fully open positions. Open top covers and use provided prop rods to keep covers in fully open position.

Splash Guard Removal - Splash Guard removal is not necessary to remove the rollers, however, it is more convenient to remove them before work is started on roller removal.

1. Remove cap screws that attach splash guard to discharge plate at discharge end of machine.

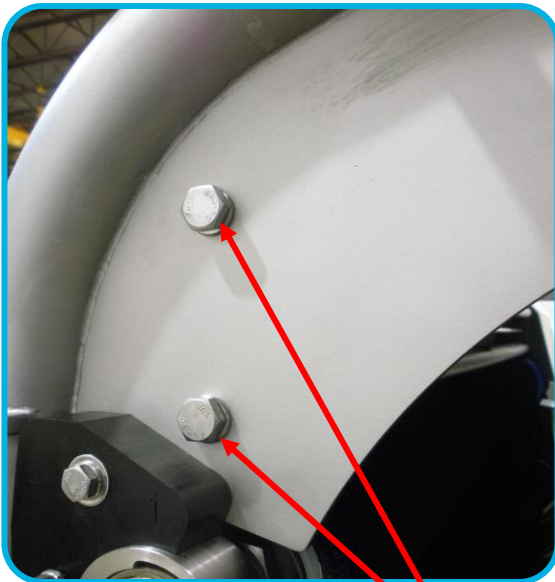

CAP SCREWS

2. From the discharge end of machine, angle splash guard towards the center of machine and pull splash guard out of peel chamber.
3. Note hole location of splash guard pins on inlet end of machine for reassembly.

CAUTION

DO NOT OPERATE MACHINE WITHOUT SPLASH GUARDS IN PLACE. IT IS RECOMMENDED TO USE ASSISTANCE FROM ANOTHER PERSON TO PREVENT INJURY FROM ERGONOMIC LIFTING AND/OR MANEUVERING ROLLS.

4.6.2 IDENTIFYING PEELING ROLLERS

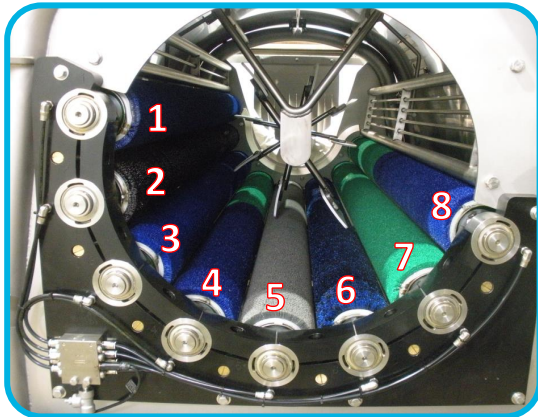

Eight (8) Roller Units

Eight (8) Roller Units: Before removing any roller shafts in chamber, identify the kind and position of roller by numbering them from 1 through 8. Rollers must be reassembled in the same position as they were originally installed, or peeling efficiency will be affected.

See Section 1.2 or 8.1 for Peeling Roll Configuration

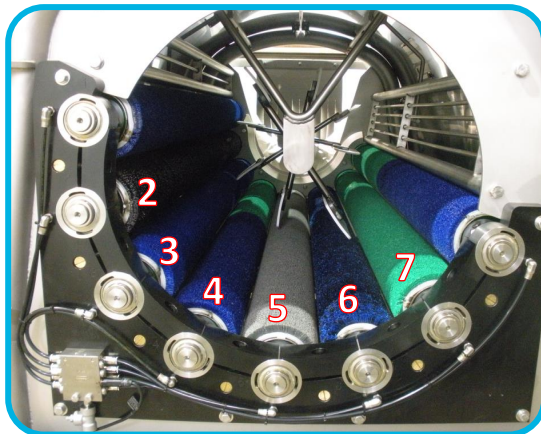

Six (6) Roller Units

Six (6) Roller Units: Before removing any roller shafts, identify the kind and position of roller by numbering them from 2 through 7. No. 1 and 8 rollers are not installed. Rollers must be reassembled in the same position as they were originally installed, or peeling efficiency will be affected.

See Section 1.2 or 8.1 for Peeling Roll Configuration

4.6.3 REMOVING PEELING ROLLER

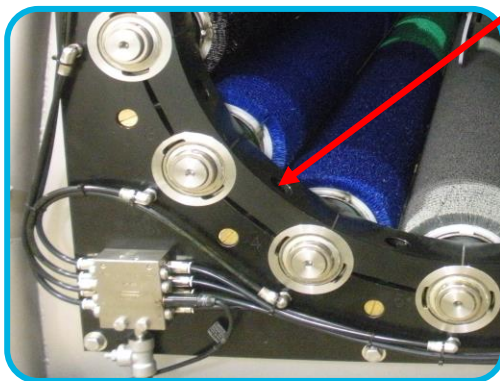

Bearing hold down block

Remove bearing hold down from the discharge end and set aside. From the side of the machine, support the roll with both hands, lifting the discharge end high enough so roller will clear end plate. At the same time, apply lateral pressure pushing the roll out through the discharge opening together with a slight twisting (rocking) motion to help release drive end (infeed end) from the drive coupler. Remove the roll from the machine. Repeat the procedure for each remaining roller.

HEAVY LIFT: USE 2 PEOPLE OR MORE

4.6.4 REASSEMBLY OF PEELING ROLLERS

1. Clean bearing block components.

NOTICE

Food grade anti-seize is applied at the factory to all bearing bores, bearing shaft, and cap screw threads in this assembly at the time of assembly. It is strongly recommended that this procedure be followed to prevent seizure of any components.

2. To reassemble, reverse the procedure in Section 4.6.1. Rollers should be replaced in No. 4 and 5 positions first, working outward to each side. See section 5.0 for the roller component list. Install rollers in pairs noting the following:
 - a. Consult the roll arrangement in Section 1.2 for the original roller arrangement. Placing each roll in the correct position is important to achieve optimum performance.

NOTICE

Your machine will be set up to perform for the application target when the machine was ordered. Products and applications change, so if you would like to revisit the roll set up provided, please reach out to the Vanmark team that can look at your processing target, and adjust rolls and/or configurations as the product evolves. We have a vast array of brushes and rolls to fit most any application you may come across and would be happy to review with you on options available.

- b. Two (2) set screws in each discharge end bearing should be loose allowing the bearing to slide freely on the shaft.
 - c. For brushes, make sure the driven end with square shaft shows the colored stripes on the brush. Similarly, with sine wave rolls, ensure their orientation is correct with the direction name stamped on the ends.
3. Guide the square end of the roller shaft into the drive coupling until the end of the shaft “bottoms out” in the coupling. **Do not use force – firm hand pressure is sufficient.**
4. Rotate the discharge end bearing until the protruding guide/button on the outer bearing housing is aligned with lubrication hole in the bottom of the half-circle bearing nest on the bearing block. Ensure the bearing is properly oriented with the lip seal towards the roll and inside of the peeling chamber. Lower the roller assembly into bearing block until the bearing is fully seated in its natural repose and the button is aligned with the lubrication hole.

-
5. Ensure the shaft is still “bottomed out” against drive coupling by applying firm hand pressure on the round end of the shaft (the shaft is free to slide through the bearing). Tighten two (2) socket head (Allen type) set screws (1/8 wrench) in each bearing with the following procedure:
 - a. Torque the first setscrew to 20-30 in-lbs.
 - b. Torque the second set setscrew to 45-50 in-lbs.
 - c. Return to the first setscrew and torque it to 45-50 in-lbs.
 6. As each pair of rollers is installed, install each bearing block cap with cap screw, lock washer and washer finger tight to ensure it is not cross-threaded. Apply a light coat of food grade anti-seize or grease onto the bolt threads prior to installation. Proceed until all rollers are installed in this manner. Caps are installed with curbed flange on each end toward inlet of machine. Flanges act as protector for roller bearing.
 7. Tighten the cap screw securely in each bearing cap. Do **NOT** tighten too tight, deforming of cap will occur.
 8. Re-install splash guards in the same fashion they were removed and close all machine covers before re-starting machine and checking roller action.

4.6.5 LOCK NUT ASSEMBLY INSTRUCTIONS

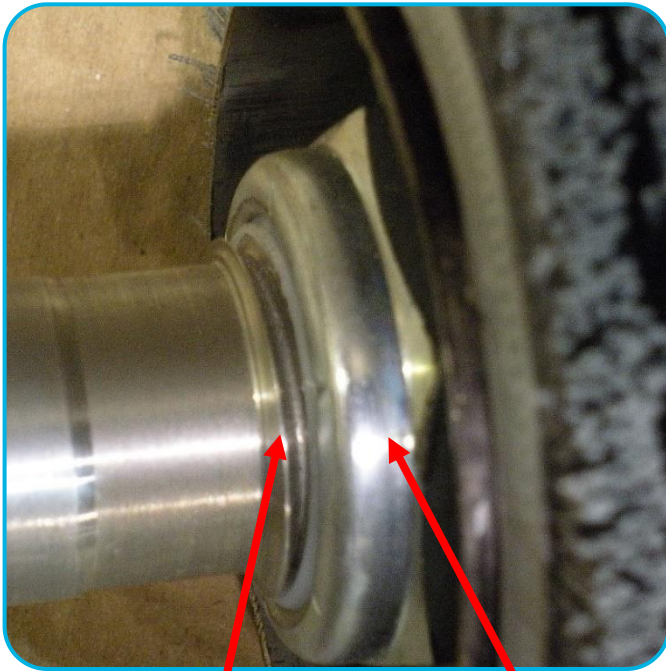

Visible Threads

Locking Nut

- Pictured (Left) illustrates the ideal locking nut position on finished roll assembly.
- There **must** be 1 to 2 full threads visible beyond the nut.
- Minimum torque required to achieve nut position should **NOT** be **LESS** than 35 ft.-lbs.
- A new locking nut is required if 3 or more threads are visible by applying less than 35 ft.-lbs. torque.

NOTICE

Tightening nut to 4 or more visible threads will cause product damage, product loss at discharge end of peeler, damage to infeed end wall plate, and brush at the infeed end.

2" Aluminum Socket



1 3/8-6 Locking Nut



4.6.6 ABRASIVE (GRIT) ROLLERS

Disassembly: A cart or rack can be helpful to store and transport peeling rolls. Contact Vanmark if you'd like a custom-built rack for storing and transporting your rolls. Having a full set of spare rolls and shafts on hand allows you to remove and replace the rolls immediately reducing the machine downtime. The roll disassembly can then be done offline in a maintenance area reducing machine downtime.

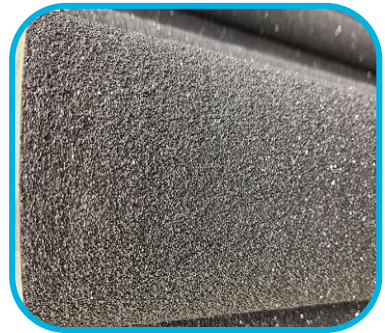

1. Once the rolls are removed, remove the bearing by loosening the set screws and sliding it off the shaft.
2. Fix the square end of the shaft to prevent the roll from rotating (this is built into our roll carts).
3. Using the provided 2" Alum. socket, loosen and remove the Locking Nut located behind the bearing (see Section 4.6.5).
4. Remove the shaft from the roll pulling from the driven square end and set it aside.

NOTICE

Be sure to use care handling the shafts and do not drop them on hard surfaces such as concrete which could bend them.

5. Remove polyurethane fixture from each end of roller and set them aside.
 - a. On occasion, the end fixtures may be stubborn to remove, especially if the roll has not been disassembled for some time. To easily remove these, drive them out from the opposite end using a wooden closet rod or dowel approximately 80" in length.
 - b. A gentle tap should be enough to get the end fixtures loose ensuring you are not driving against the welded lugs inside the tube and just against the end fixture. Prying out the end fixtures may damage them so they can't be re-used.
6. Clean all components and inspect them for unusual wear or damage. Refer to Section 7.0 for spare parts if needed.

Reassembly: Re-assembly is essentially the same as the disassembly process in reverse. Position the new roll on a stable surface such as a cart or workbench.

1. Install polyurethane fixture on drive end of roller. A light coat of food grade grease on the outer diameter of the end fixture can help with installation. Ensure the keys inside the roll are aligned with the notches on the end fixture and it's properly fully seated over the keys

- a. **NOTE:** For rollers having more than one grade of abrasive "grit", use the larger (coarsest) abrasive on the driven/infeed end. This end is mounted at the inlet or drive end of machine; also, rollers that have notches go toward drive end.

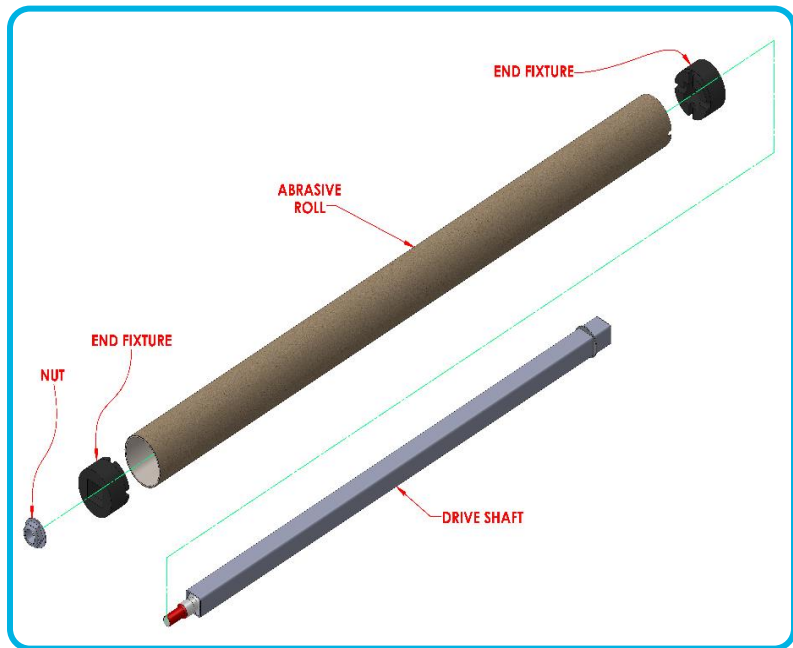

2. Insert the round end of the shaft into the driven end of the roll through the center of the end fixture. Make sure with brushes, the shaft is inserted into the end with the colored stripes. As the shaft is inserted, align the square shaft with the square opening of the end fixture. Continue to slide the shaft through until the washer at square end is flush with the end fixture. Care should be taken to not damage threads on bearing shaft by striking roller tube lugs.
3. Elevate the shaft to the center of the roller and slide the second polyurethane end fixture over the bearing end of drive shaft. Ensure it is aligned with the keys/lugs inside the roll and with the square shaft. A little food grade grease on the ID of the tube can help with installation. Gently tap the end fixture into the roll until it is fully seated (take care to not tap on the shaft end).
4. Install the 1 3/8–6 locking nut by hand onto the shaft threads with the flat washer towards the end fixture. Before tightening nut securely, center polyurethane fixture in roller for smooth operation. With the square/driven end of the shaft fixed, tighten the nut using the supplied socket wrench.

NOTICE

DO NOT over tighten the locking nut as damage can occur. See Section 4.6.5 for locking nut assembly instructions. Tighten the nut until 1-2 full threads are visible beyond the nut and the torque should exceed 35 ft.-lbs. If 3 or more threads are visible with less than 35 ft.-lbs. of torque applied, the nut requires replacement.

When the nut is properly tightened, it will eliminate any play in the ends of the shafts, between the end fixtures and tube.

4.6.7 SINEWAVE ABRASIVE SEGMENTS

Disassembly: A cart or rack can be helpful to store and transport peeling rolls. Contact Vanmark if you'd like a custom-built rack for storing and transporting your rolls. Having a full set of spare rolls and shafts on hand allows you to remove and replace the rolls immediately reducing the machine downtime. The roll disassembly can then be done offline in a maintenance area reducing machine downtime.



1. Remove the bearing and 1-3/8-6 locking nut using the 2" aluminum socket provided with machine.
2. Place a wooden board of suitable size on the floor. Hold the roll vertically with the bearing (threaded) end facing down. Strike the board with the entire roller assembly. This should loosen segments from shaft and shift them towards the threaded bearing end on the shaft. Repeat procedure if segments do not come loose the first time.

NOTICE

Do NOT strike bearing shaft on bare floor or with hammer. Resulting damage might require dressing down or replacement.

3. Remove segments from bearing end of shaft one at a time. The stop washer on the driven end of the shaft prevents removal from the drive (square) end.
4. Clean all components thoroughly and inspect for abnormal wear or damage. If questionable replace now.

Reassembly

1. Stage the new abrasive segments by standing them on end so that stamped word (either right or left) is facing up. If more than one grade of abrasive segment is installed on same shaft, coarsest grit segments ordinarily go next to the drive (square) end of shaft and are installed first.
2. Rest the driven/square end of the shaft on the floor and support the bearing end such that the shaft is vertical. Place segments on shaft with the stamped word facing upwards towards the threaded bearing end of the shaft. Slide it toward drive end until the stop washer is seated in recess of segment.
3. Repeat the procedure to install the remaining four (4) segments. Always keep the stamped word towards the bearing end of the shaft and in direct line with the word on the segment previously installed (aligned with same square side of the shaft).

NOTICE

DO NOT install right and left segments on same shaft. Segment can be determined right or left-handed by looking along its length from either end. If helix or "high" part of wind curves to your left, it is left-handed; if it curves to the right, it is right-handed.

4. Install 1 3/8-6 locking nut and tighten securely. Segments must not appear to be loose on shaft; however, **DO NOT** over tighten as damage to segments can occur.

NOTICE

DO NOT over tighten the locking nut as damage can occur. See Section 4.6.5 for locking nut assembly instructions. Tighten the nut until 1-2 full threads are visible beyond the nut and the torque **should exceed 35 ft.-lbs.** If 3 or more threads are visible with less than 35 ft.-lbs. of torque applied, the nut requires replacement.

When the nut is properly tightened, any play between the sine wave segments and tube should be eliminated.

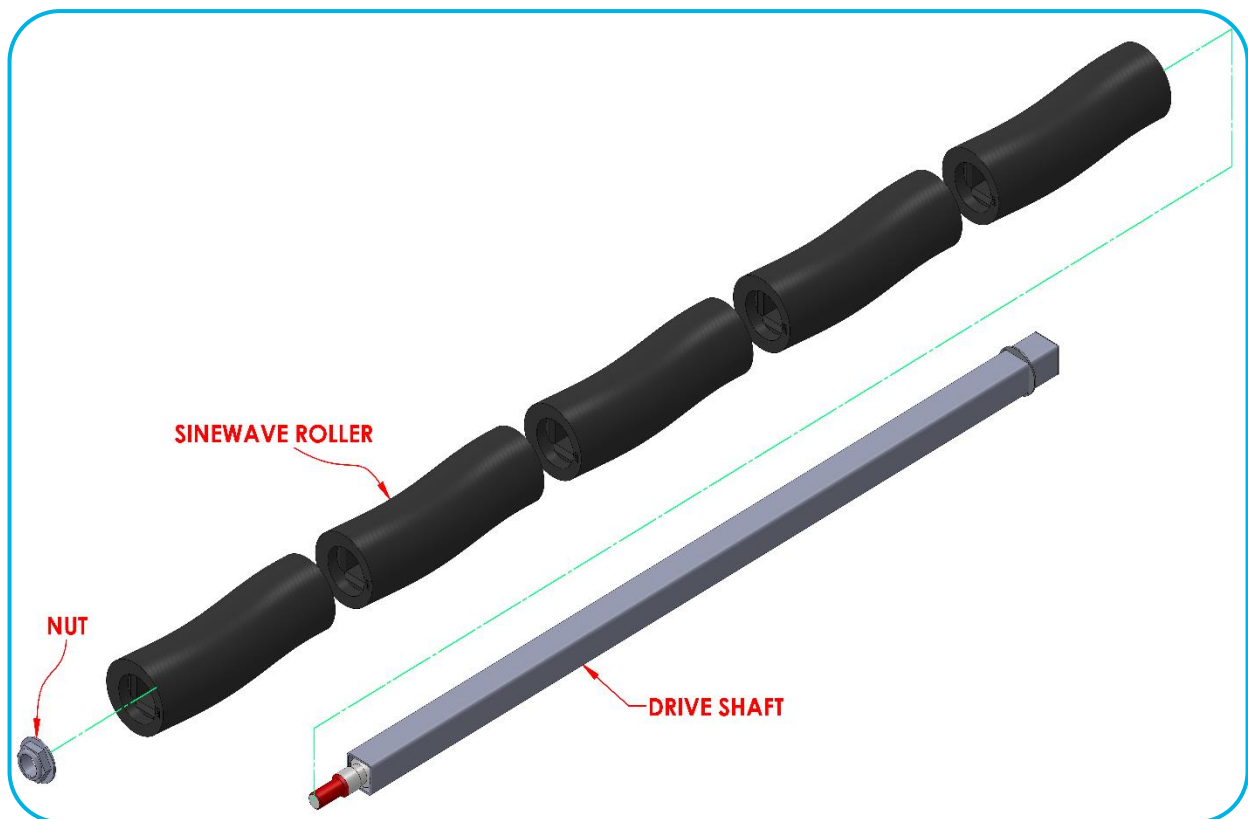

4.6.8 TIMING THE DRIVE ROLLERS (SINE WAVE ONLY)

Coordinated rotation of rollers is only required with sine wave rollers and only possible in machines using mechanical drive cases. This is referred to as “timing” the rolls (to one another) and is a critical step when re-installing sine wave style rolls into your machine.

NOTICE

Failure to properly set up roll timing with sine wave roll types can result in damage to the rolls, drive system, or cause damage and/or loss of product.

1. To time sinewave abrasive rollers, rotate mechanical drive case so that the sides of the square openings in couplings are in a horizontal and vertical position.
2. Install abrasive rollers into the machine with the driven end properly inserted into the drive coupler, and with the embossed word “left” or “right” on the segment end closest to discharge bearing is in the same position. The position of the word on the first shaft installed is not important but keeping all the words of succeeding rollers in same position as the first is critical.

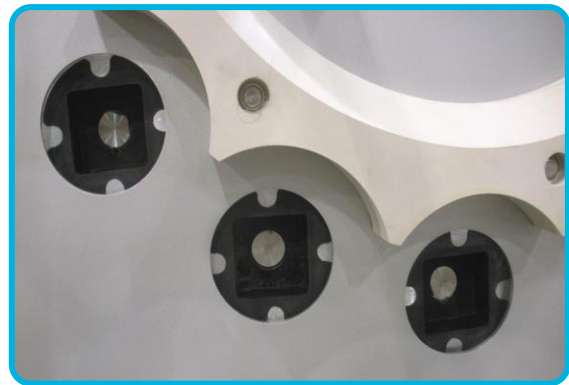



☐ = INDICATES LOCATION OF "RIGHT" OR "LEFT" TEXT EMBOSSEMENT

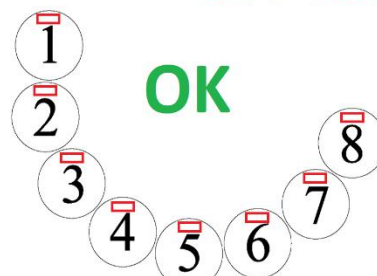

OK

DISCHARGE END VIEW



NOT OK

DISCHARGE END VIEW

4.6.9 BRUSH ROLLERS

Disassembly: A cart or rack can be helpful to store and transport peeling rolls. Contact Vanmark if you'd like a custom-built rack for storing and transporting your rolls. Having a full set of spare rolls and shafts on hand allows you to remove and replace the rolls immediately reducing the machine downtime. The roll disassembly can then be done offline in a maintenance area reducing machine downtime.

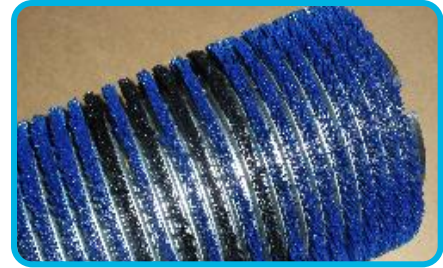

1. Once the rolls are removed, remove the bearing by loosening the set screws and sliding it off the shaft.
2. Fix the square end of the shaft to prevent the roll from rotating (this is built into our roll carts).
3. Using the provided 2" Alum. socket, loosen and remove the Locking Nut located behind the bearing (see Section 4.6.5).
4. Remove the shaft from the roll pulling from the driven square end and set it aside.

NOTICE

Be sure to use care handling the shafts and do not drop them on hard surfaces such as concrete which could bend them.

5. Remove polyurethane fixture from each end of roller and set them aside.
 - a. On occasion, the end fixtures may be stubborn to remove, especially if the roll has not been disassembled for some time. To easily remove these, drive them out from the opposite end using a wooden closet rod or dowel approximately 80" in length.
 - b. A gentle tap should be enough to get the end fixtures loose ensuring you are not driving against the welded lugs inside the tube and just against the end fixture. Prying out the end fixtures may damage them so they can't be re-used.
6. Clean all components and inspect them for unusual wear or damage. Refer to Section 7.0 for spare parts if needed.

Reassembly: Re-assembly is essentially the same as the disassembly process in reverse. Position the new roll on a stable surface such as a cart or workbench. Make sure to note one end has a series of colored stripes to identify the infeed/driven end of the brush. The stripes must be nearest the square (driven) end of the shaft.

NOTICE

With brushes, the stripes must be nearest the square (driven) end of the shaft and after installed in the machine, near the infeed end. The brushes are uniquely manufactured to Vanmark's specifications requiring this orientation. If installed incorrectly, the machine will not perform as designed and result in reduced performance or damage to the product or brush.

1. Install polyurethane fixture on drive end of roller. A light coat of food grade grease on the outer diameter of the end fixture can help with installation. Ensure the keys inside the roll are aligned with the notches on the end fixture and it's properly fully seated over the keys
 - a. **NOTE:** For rollers having more than one grade of abrasive "grit", use the larger (coarsest) abrasive on the driven/infeed end. This end is mounted at the inlet or drive end of machine; also, rollers that have notches go toward drive end.

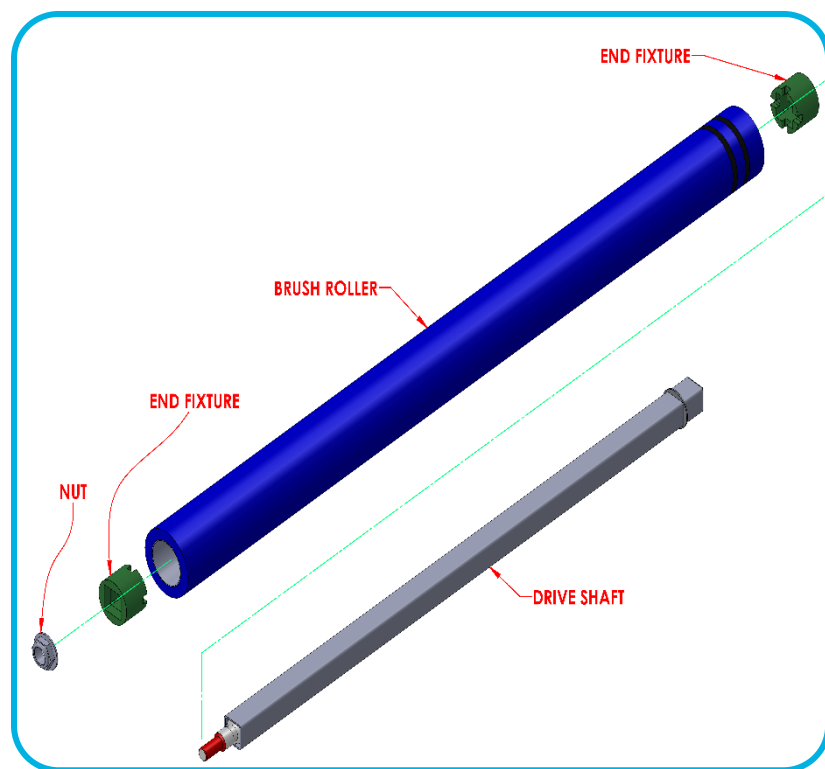

2. Insert the round end of the shaft into the driven end of the roll through the center of the end fixture. Make sure with brushes, the shaft is inserted into the end with the colored stripes. As the shaft is inserted, align the square shaft with the square opening of the end fixture. Continue to slide the shaft through until the washer at square end is flush with the end fixture. Care should be taken to not damage threads on bearing shaft by striking roller tube lugs.
3. Elevate the shaft to the center of the roller and slide the second polyurethane end fixture over the bearing end of drive shaft. Ensure it is aligned with the keys/lugs inside the roll and with the square shaft. A little food grade grease on the ID of the tube can help with installation. Gently tap the end fixture into the roll until it is fully seated (take care to not tap on the shaft end).

4. Install the 1 3/8–6 locking nut by hand onto the shaft threads with the flat washer towards the end fixture. Before tightening nut securely, center polyurethane fixture in roller for smooth operation. With the square/driven end of the shaft fixed, tighten the nut using the supplied socket wrench.

NOTICE

DO NOT over tighten the locking nut as damage can occur. See Section 4.6.5 for locking nut assembly instructions. Tighten the nut until 1-2 full threads are visible beyond the nut and the torque should exceed 35 ft.-lbs. If 3 or more threads are visible with less than 35 ft.-lbs. of torque applied, the nut requires replacement.

When the nut is properly tightened, it will eliminate any play in the ends of the shafts, between the end fixtures and tube.

4.6.10 TWO PIECE BRUSH ASSEMBLY

Much like a standard brush assembly, a two-piece brush assembly provides a different roll arrangement option with coarser brush filaments at the infeed end and softer elements towards the discharge end. The idea is the coarser infeed end does the “heavy lifting” of breaking through tough product skin or protective layers while the softer discharge end, is gentle on the product after the tougher protective layer is removed to minimize product damage or yield loss.

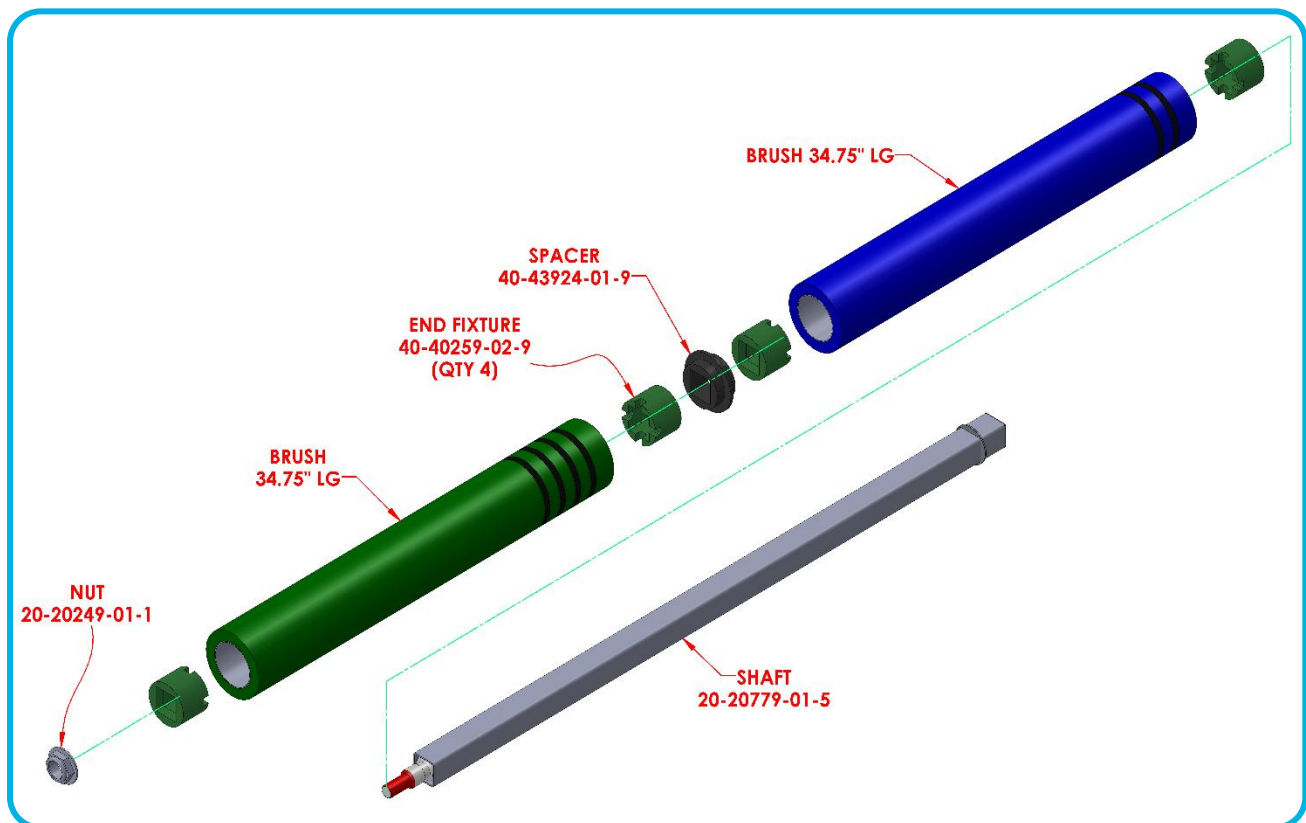

Disassembly

1. Repeat steps described in the Brush Roller disassembly with one difference:
 - a. There are (2) additional end fixtures and a Spacer which is located between the (2) brush halves
 - b. Like a full-length brush, each brush half, receives an end fixture in each end; (4 total)
2. Clean all components thoroughly and inspect for abnormal wear or damage. If questionable, replace now.

Reassembly: Re-assembly is essentially the same as the disassembly process in reverse. Position the new roll on a stable surface such as a cart or workbench. Make sure to note one end of each brush has a series of colored stripes to identify the infeed/driven end of the brush. The stripes must be nearest the square (driven) end of the shaft.

NOTICE

With brushes, the stripes must be nearest the square (driven) end of the shaft and after installed in the machine, near the infeed end. The brushes are uniquely manufactured to Vanmark's specifications requiring this orientation. If installed incorrectly, the machine will not perform as designed and result in reduced performance or damage to the product or brush.

1. Install a polyurethane end fixture on the drive end of each brush segment (end with stripes). A light coat of food grade grease on the outer diameter of the end fixture can help with installation. Ensure the keys inside the roll are aligned with the notches on the end fixture and it's properly fully seated over the keys
 - a. **NOTE:** For two-piece brushes, the coarsest abrasive should be positioned on the driven/infeed end of the roll. This end is mounted at the inlet or drive end of machine; also, rollers that have notches go toward drive end.
2. Insert the round end of the shaft into the driven end of the coarser brush segment first through the center of the end fixture. Make sure with brushes, the shaft is inserted into the end with the colored stripes. As the shaft is inserted, align the square shaft with the square opening of the end fixture. Continue to slide the shaft through until the washer at square end is flush with the end fixture. Care should be taken to not damage threads on bearing shaft by striking roller tube lugs.
3. Elevate the shaft to the center of the roller and slide the second polyurethane end fixture over the bearing end of drive shaft. Ensure it is aligned with the keys/lugs inside the brush segment and with the square shaft. A little food grade grease on the ID of the tube can help with installation. Gently tap the end fixture into the roll until it is fully seated (take care to not tap on the shaft end).

4. Slide the Spacer over the round bearing end of the shaft aligning the square bore to the square shaft until is fully nested against the end fixture of the first brush segment.
5. Now install the second brush segment by inserting the bearing end of the shaft, through the end fixture in the striped end of the brush segment. The second brush segment will be located towards the discharge end of the peeler and is typically a softer, less abrasive brush than the first.
6. Elevate the shaft to the center of the roller and slide the last polyurethane end fixture (second end fixture in the second brush segment) over the bearing end of drive shaft. Ensure it is aligned with the keys/lugs inside the brush segment and with the square shaft. A little food grade grease on the ID of the tube can help with installation. Gently tap the end fixture into the roll until it is fully seated (take care to not tap on the shaft end).
7. Install the 1 3/8–6 locking nut by hand onto the shaft threads with the flat washer towards the end fixture. Before tightening nut securely, center polyurethane fixture in roller for smooth operation. With the square/driven end of the shaft fixed, tighten the nut using the supplied socket wrench.

NOTICE

DO NOT over tighten the locking nut as damage can occur. See Section 4.6.5 for locking nut assembly instructions. Tighten the nut until 1-2 full threads are visible beyond the nut and the torque should exceed 35 ft.-lbs. If 3 or more threads are visible with less than 35 ft.-lbs. of torque applied, the nut requires replacement.

When the nut is properly tightened, it will eliminate any play in the ends of the shafts, between the end fixtures and tube.

4.6.11 PINTLE ROLLERS:

Refer to Section 4.6.7 for disassembly and assembly instructions for sinewave abrasive rollers. The process is the same except:

1. Pintle rollers are straight; not sinusoidal. This means pintle segments do not require timing or specific alignment so those portions of the assembly/disassembly may be ignored.
2. Spacers are required between each pintle segment.
During disassembly, set aside the spacers to be re-used during re-assembly.

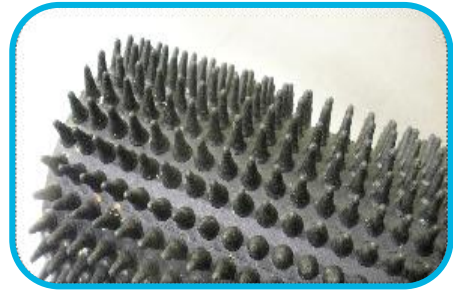

NOTICE

Spacers **MUST BE INSTALLED** between each pintle segment. **DO NOT** over tighten the locking nut as damage can occur. See Section 4.6.5 for locking nut assembly instructions. Tighten the nut until 1-2 full threads are visible beyond the nut and the torque should exceed 35 ft.-lbs. If 3 or more threads are visible with less than 35 ft.-lbs. of torque applied, the nut requires replacement.

When the nut is properly tightened, it will eliminate any play in the ends of the shafts, between the end fixtures and tube.

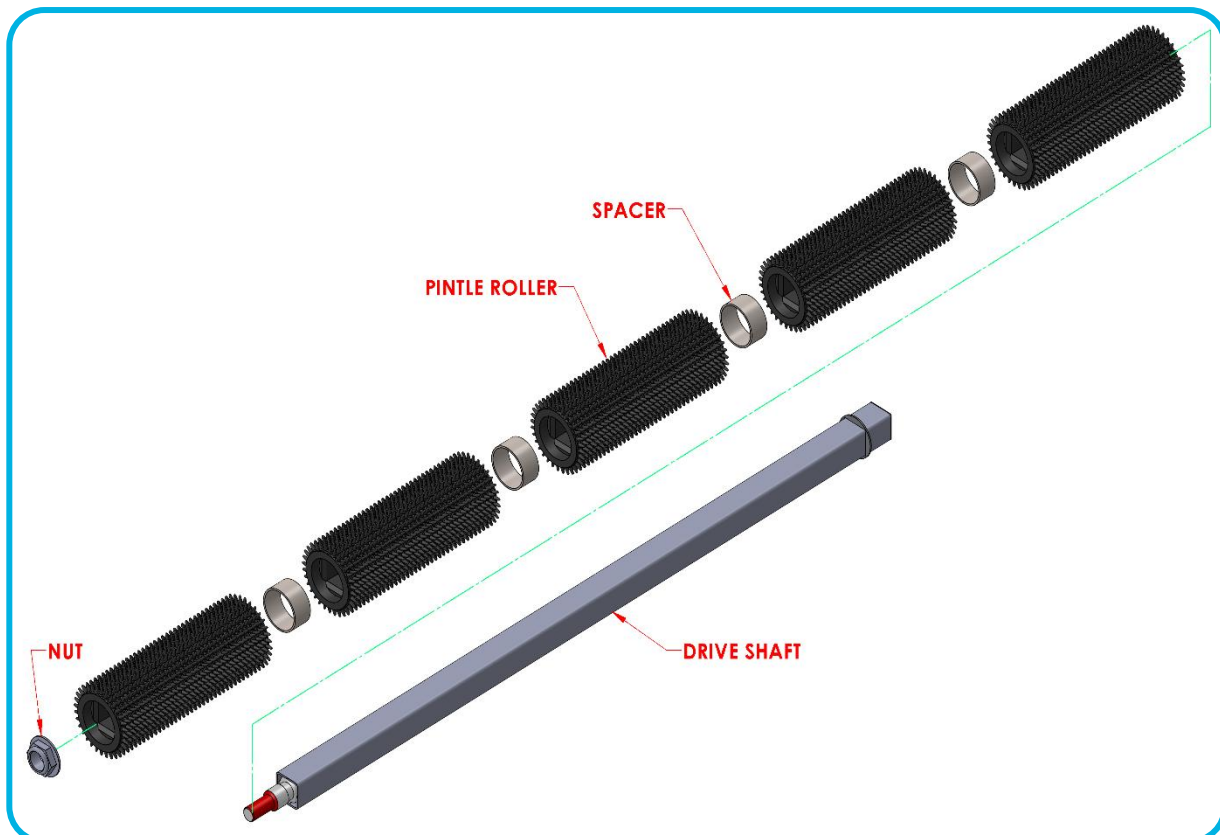

4.7 BELT DRIVE

Consists of a drive sprocket with hub, driven pulley with hub, and a self-tracking drive belt. The belt drive must be disassembled to remove the drive case, replace drive case components on rollers 4 and 5, or to replace belt drive parts.

⚠ WARNING

The Belt Drive is covered by a Fixed Guard. Anytime the guard is removed for access, ensure that drive is not unexpectedly started. Turn off and lock out power source before proceeding. Failure to observe these precautions could result in bodily injury.

Always ensure the fixed guard is properly secured during re-installation prior to restarting the machine or applying power.

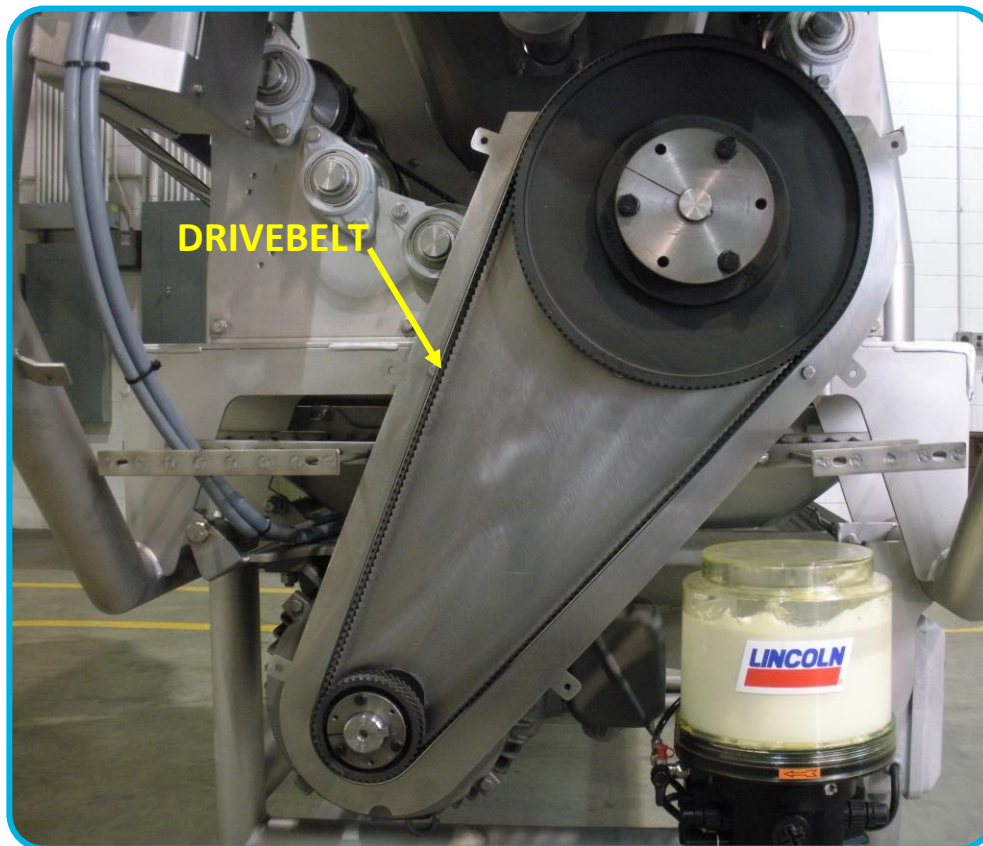

4.7.1 DRIVE BELT REPLACEMENT

WARNING

To ensure that drive is not unexpectedly started, turn off and lock out power source before proceeding. Failure to observe these precautions could result in bodily injury.

1. Remove the drive compartment panel on inlet end of machine by removing four (4) 1/4" bolts.
2. Remove five (5) 7/16" bolts that retain the belt cover.
3. Loosen the belt tension fastener at the motor mount to remove tension from the belt and remove the belt.
 - a. ***Note:** It may be helpful to mark the tensioning position prior to loosening for reference during re-installation. A new belt may not return to the exact same tension position (see step 6 below) but the mark can provide a reference point.
4. Place the belt on each sprocket and ensure proper engagement between the sprocket and belt teeth.
5. Lengthen the center distance to remove any belt slack by adjusting the tensioning fasteners at the motor mount.

NOTICE

Notice the Self-Tracking belt tooth direction. This must align with the drive sprockets and properly engage with the sprocket teeth. Verify the small sprocket on the motor and the large driven sprocket are properly aligned with the belt teeth. Sprockets should be centered on the belt width. Failure to properly align the belt teeth with sprockets could result in damage to the belt.

6. After tensioning, the belt should have 3/8" (0.375 in.) deflection in belt with 24 lbs. of force applied to span length of belt.
7. Lock down the center distance adjustments and re-check the sprocket alignment after the belt is properly tensioned.
8. Re-check the belt tension and alignment after 8 hours of operation to ensure the drive has not shifted.

4.7.2 PULLEYS AND PULLEY HUB BUSHINGS

Disassembly

WARNING

The Belt Drive is covered by a Fixed Guard. Anytime the guard is removed for access, ensure that drive is not unexpectedly started. Turn off and lock out power source before proceeding. Failure to observe these precautions could result in bodily injury. Always ensure the fixed guard is properly secured during re-installation prior to restarting the machine or applying power.

1. **SHUT-OFF AND LOCK-OUT ELECTRICAL POWER** to prevent accidental starting.
2. Remove drive compartment panel, belt cover, and drive belt as described in Section 4.7.1.
3. Loosen and remove cap screws in bushing.
4. Insert cap screws in tapped removal holes and progressively tighten each one until pulley is loose from the bushing.
5. Remove the pulley from the bushing.
6. Remove the bushing from the shaft.

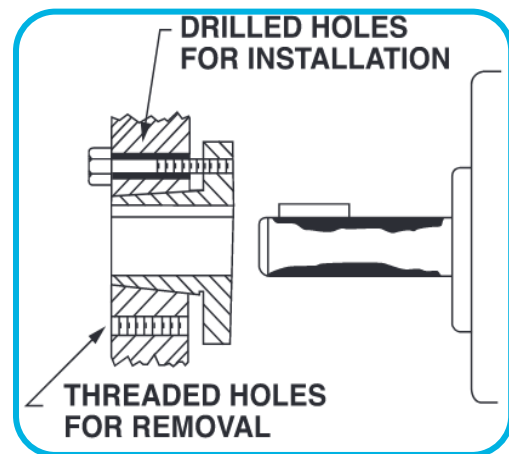

Reassembly

1. Thoroughly inspect bore of mating part and tapered surface of bushing. Any paint, dirt, oil, or grease must be removed.

NOTICE

Do **NOT** use lubricants on the bushing. Food-grade Anti-seize may be used on the bolts and shaft OD only, not between the bushing and sprocket.

2. Insert bushing into pulley and loosely insert cap screws into bushing and pulley.
3. With the key in the key seat of the shaft, slide the assembly onto the shaft aligning the key/keyway. If it is difficult to slide the bushing onto the shaft, wedge a flat screwdriver blade or similar item into the bushing's compression slit to relieve the compression.
4. Position the assembly on the shaft and align it with a straightedge against the outside edge of the small and large drive belt pulleys. Adjust the pulleys until the straightedge touches two (2) outside and two (2) inside edges of the pulleys and both pulleys have proper shaft engagement. (Straightedge should cross pulleys as near shaft as possible.)
5. Tighten cap screws evenly and progressively until obtaining correct torque of 40 ft-lbs. There must be a gap between the bushing flange and mating hub when installation is complete. Replace the drive belt as described in Section 4.7.1 and replace covers.

4.8 MECHANICAL ROLLER DRIVE CASE

The mechanical drive case transfers power from the drive motor to each of the peeler rolls. It consists of a series of interconnected sprockets and belts. The drive case is a sub-assembly that can be removed from the machine while remaining mostly assembled except from the main drive sprocket. Repair of sub-components is possible without removal of the entire drive case unit from the machine. However, major repair is more easily accomplished with entire unit removed from machine. See Section 5.0 for parts and dimensions.

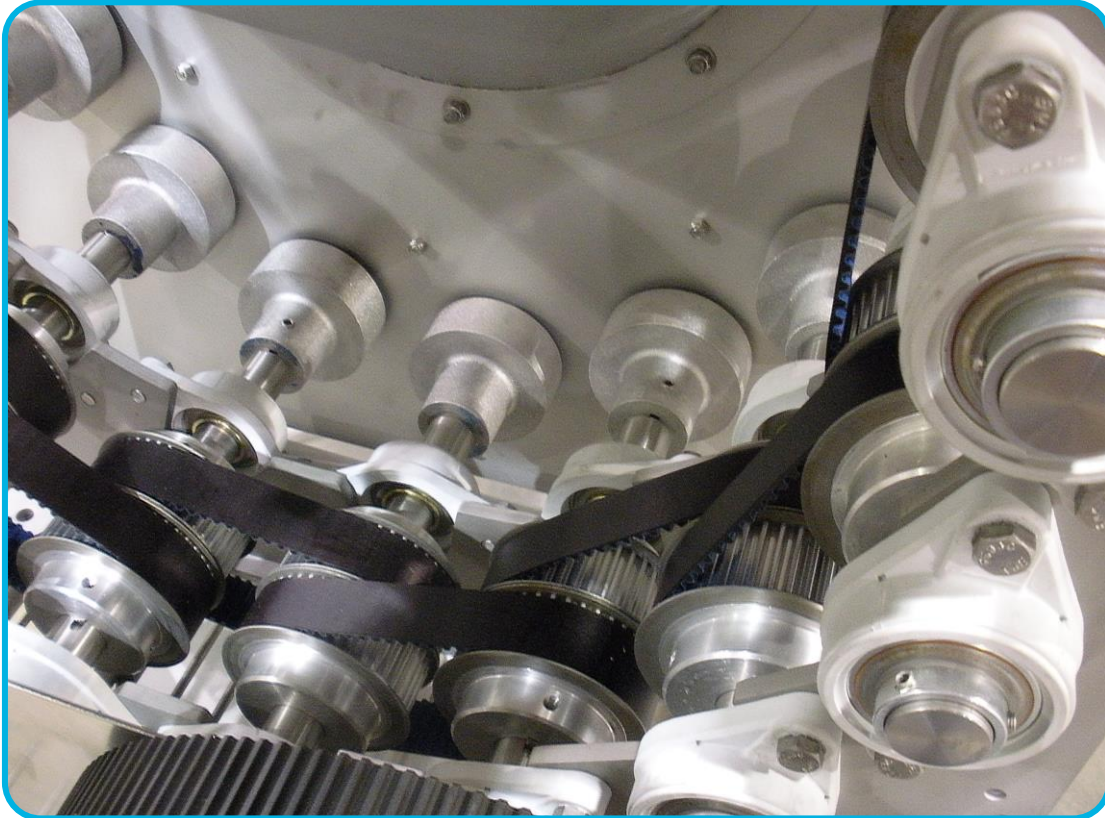

4.8.1 DRIVE CASE REMOVAL AND INSTALLATION

⚠ WARNING

To ensure that drive is not unexpectedly started, turn off and lock out power source before proceeding. Failure to observe these precautions could result in bodily injury.

1. **SHUT-OFF AND LOCK-OUT ELECTRICAL POWER** to prevent accidental starting.
2. Remove all peeling rollers as described in Section 4.6.1
3. Remove drive panels, and drive belt as described in Section 4.7.1.
4. Remove three (3) 1/2" bolts that retain the drive belt cover backing plate and rotate it down out of the way; it does not need to be removed from the motor.

5. Loosen four (4) 3/4" bolts that hold the drive case to the drive mount. **Note:** Keep any shims/washers used to position the drive couplers in the roll openings of the frame.
6. Use a lifting device to lift the drive case up and off the mount sliding it out the right-hand side of machine. Due to the roll orientation and trapped key components, it can only go out the back or right-hand side of the machine.
7. To install the drive case sub-assembly, reverse steps 1-7 above including any shims removed in step 5.

4.8.2 DRIVE SHAFT AND ROLL SHAFT REPLACEMENT

The design of drive case makes it necessary to remove the outer most shafts first, working towards the center of the drive case until the desired shaft or belt is reached for replacement. Drive case dimensions and part identification can be found in Section 5.0. Drive coupling removal and installation can be found in the next section below.

4.8.3 ROLLER DRIVE COUPLING (ALUMINUM)

The drive coupling provides support for the drive end of each roller and transfers power to the peeling bed rollers. No maintenance or adjustment is required for day-to-day operation. Visual inspection on a regular basis should be made for cracks in the casting, loose or missing set screws and excessive play between the coupling and drive shaft. When any peeling rollers are removed from machine, careful inspection of urethane mold should be made. Check for excessive wear or deformation in the square opening, softness of the urethane mold, and that the urethane is firmly adhered to the casting. Replace the coupling if any one of these conditions are found. Drive couplings are bored to a very close press-fit tolerance on the round drive shaft utilizing a heat-shrink process to install them onto the drive shafts.

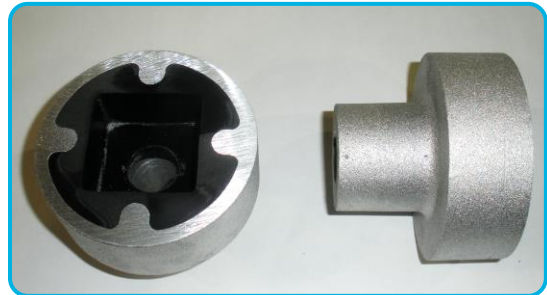

NOTICE

DO NOT:

- Increase bore diameter of coupling.
- Decrease (dress down) overall size of output shaft.
- Overheat casting to point of melting or modify urethane mold.
- Use undue force when mounting coupling.

Disassembly

1. Remove the drive case and drive shaft from the machine as described in Sections 4.8.1 & 4.8.2.
2. Loosen the set screw in the drive coupling being replaced.
3. Remove the coupling from shaft using a gear puller and heat, if required. Use care when applying heat (see Notice above).

Reassembly

1. Check key in output shaft keyway for nicks. Replace if necessary.
2. Clean any foreign material from the surface of the output shaft. Do not reduce or modify the outer diameter of the shaft.
3. Remove any nicks or burrs from the bore and keyway of coupling. Do not enlarge the inside bore diameter.
4. Remove the set screws from the coupling.
5. Place the coupling on a solid flat work area with the urethane side down. Apply heat with torch for a few moments to the external part of coupling bore. **Do not overheat** causing the aluminum or urethane to melt. Rotate the coupling during heating to distribute the heat evenly.

WARNING

Always wear appropriate eye protection. Use heavy gloves as aluminum couplings become too hot to handle with bare hands. Take care to NOT OVERHEAT the coupling as it could cause damage to the part.

6. Align the keyways of the shaft and coupling pushing the heated coupling onto the shaft until it bottoms out against the step on the shaft.
7. Correctly heating the casting and quickly installing it onto the shaft will allow the coupling to "slip" onto the mating shaft quite easily.
8. Immerse the coupling in coolant (ie. Water) immediately after installation to preserve the urethane and its bond to the casting. Reinstall set screws and torque to 120 inch-lbs.

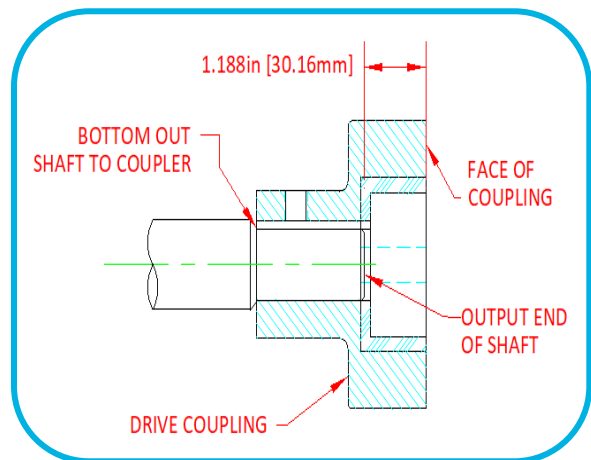

4.8.4 ROLLER DRIVE COUPLING (QUICK CHANGE)

The Quick-Change Coupler (std.) outfits the machine with an alternate version of the drive coupler (refer to Section 4.8.3 for details) that allows for quick disassembly and re-assembly.

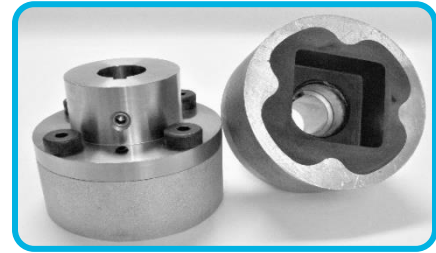

Disassembly

1. Remove the Drive Case access panel from the sides or end of the machine.
2. Loosen the (4) large shoulder bolts on the backside of the quick-change hub but do not remove. The heads of the shoulder bolts should be raised from the hub face.
3. Progressively tighten the (2) small set screws on the hub face to “push” the aluminum coupler away from the hub.
4. Once the coupler is loose from the hub, loosen the (2) set screws to relieve pressure, and remove the (4) shoulder bolts and aluminum coupler.

Reassembly

1. Inspect key in output shaft keyway for nicks. Replace if necessary.
2. Clean any foreign material from surface of output shaft. Do not reduce overall diameter of shaft.
3. Remove any nicks or burrs from bore and keyway of coupler. Do not enlarge inside bore diameter.
4. Loosen set screws in Machined Hub.
5. Install Machined Hub onto drive shaft until the end faces of the Machined Hub and drive shaft are flush (see image right). Tighten (2) Set Screws to lock the Machined Hub to the drive shaft.
6. Align the Coupling center with the bore of the Machined Hub and the (4) bolt holes. Ensure the Coupling is fully seated, flat, and flush with the Machined Hub.
7. Insert and finger-tighten the (4) Shoulder Bolts through the Machined Hub and into the Coupling. Torque the (4) Shoulder Bolts to 12-16 ft-lbs.

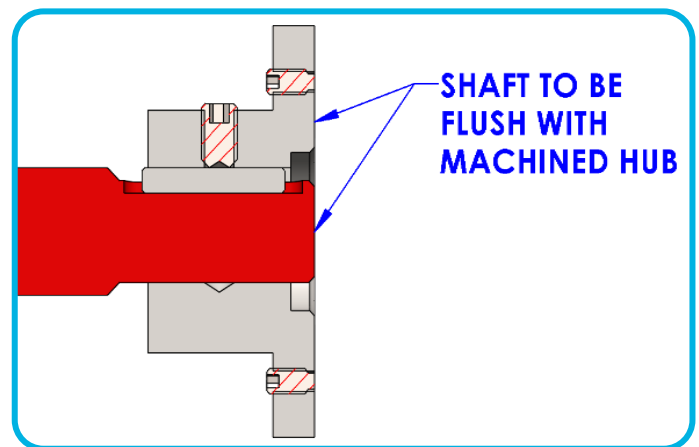
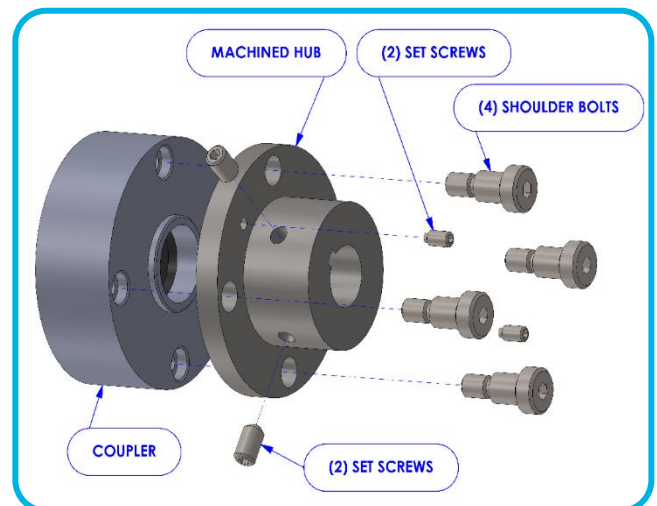

Quick Change Coupler Parts Overview

The quick-change coupler is a two-piece design; with the urethane insert half being removed and replaced without removing the shaft or drivecase from the machine; significantly reducing service time.

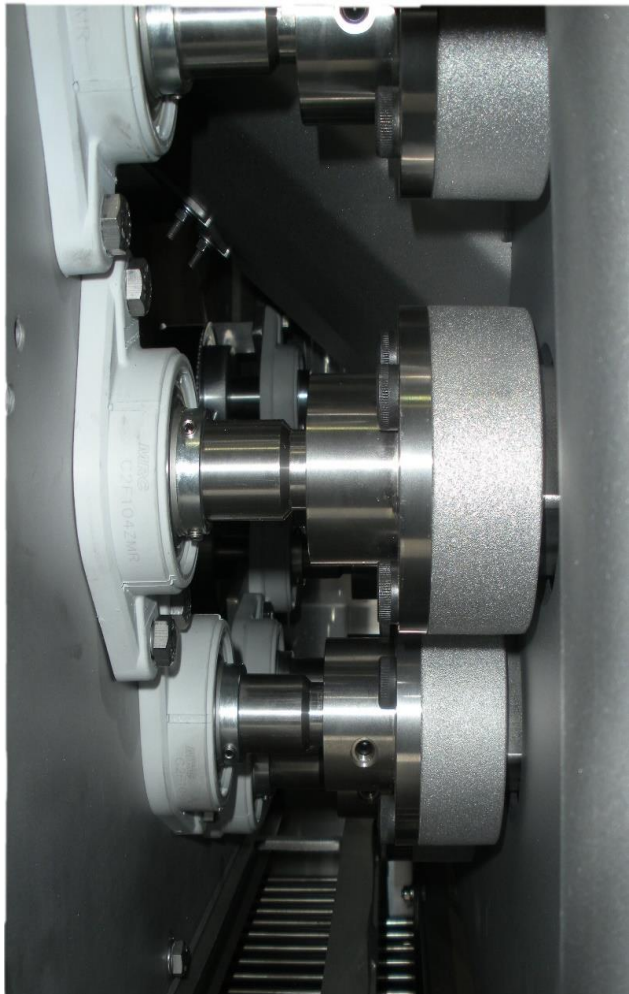

Quick Change Coupler Kit

Complete Coupler
P/N 60-60660-01-5



Coupler Mount Hub
With Set Screws

P/N 50-59360-01-5



Replaceable Coupler
With 4 Bolts

P/N 50-59359-01-9

Bolts can be ordered
individually

P/N 48-48398-01-5



5.0 PARTS

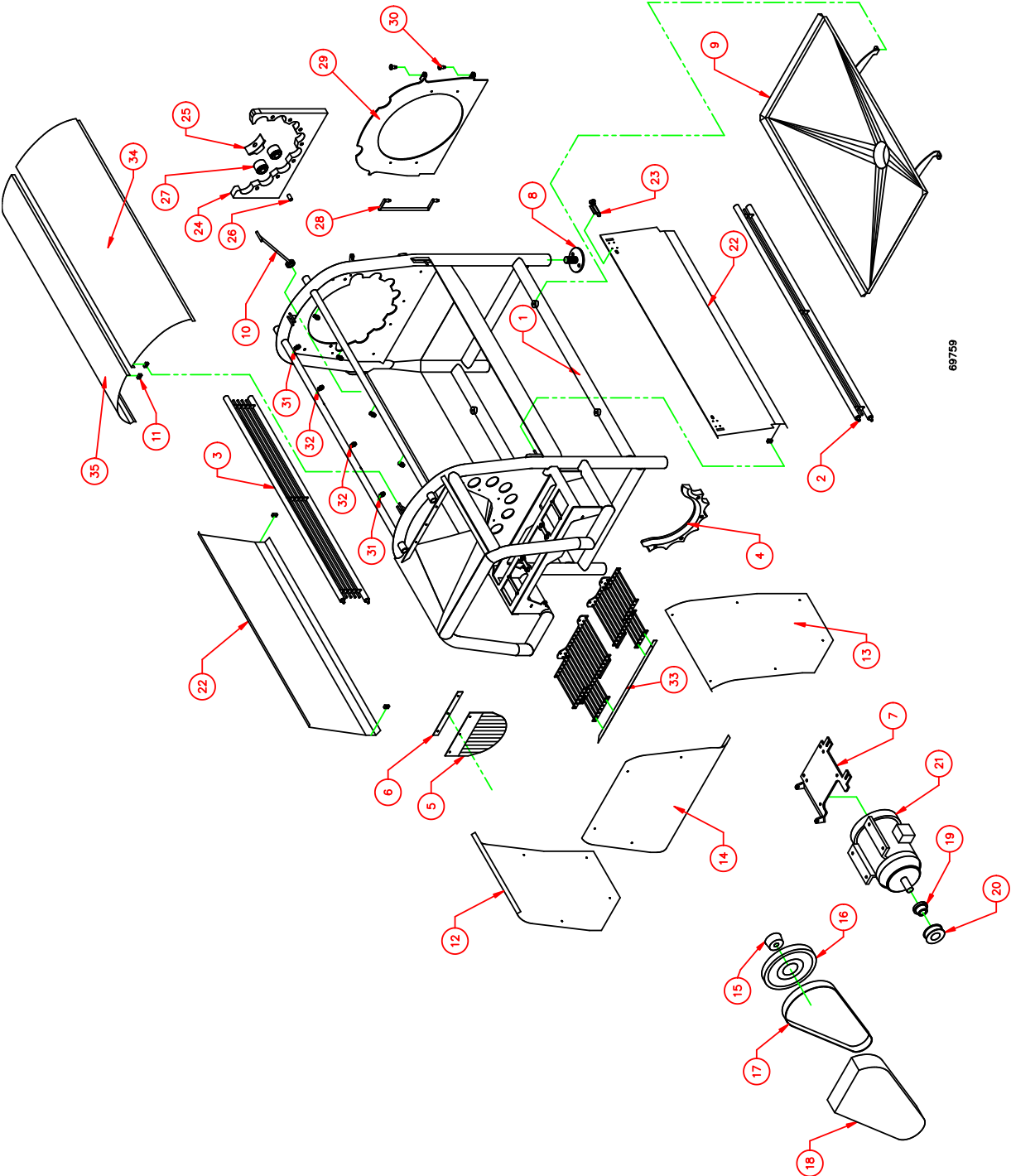

To feed our growing world - Together

300 Industrial Parkway, Creston, IA 50801, USA
Phone: +1 740-201-0004
vanmark.com

02920 / 02922 PEELER MANUAL
REV. A 2020

5.1 02920 (IMPERIAL) PART IDENTIFICATION

NOTICE

**** Part listed is for standard machine. See Section 1.2 Data Sheet and Section 6.0 for available options/alternate part numbers**

REF. NO	PART NUMBER	NO. REQ.	DESCRIPTION
1	20-26062-01-5	1	Frame, 2920 Peeler
2	20-25410-01-5	1	Right Hand Splash Guard – 8 Roll- before ser. no. 029200040
	20-26066-02-5	1	Right Hand Splash Guard - 8 Roll – after ser. no 029200039
	20-26357-02-5	1	Right Hand Splash Guard - 6 Roll
3	20-25410-02-5	1	Left Hand Splash Guard – 8 Roll- before ser .no 029200040
	20-26066-01-5	1	Left Hand Splash Guard – 8 Roll – after ser. no. 029200039
	20-26357-01-5	1	Left Hand Splash Guard - 6 Roll
4	40-43770-01-9	1	Product Protector
5	30-39014-01-9	1	Product Retention Drape
6	30-38953-01-5	1	Clamp, Product Retention Drape
7	20-25404-01-5*	1	Pivot Plate, 2920 Motor Mount 256T
	See Section 1.2**	1	Pivot Plate, 2920 Motor Mount 256T 1P
8	20-24952-01-5	4	Leveling Leg
9	See Section 1.2	1	Drain Pan Assy.
		1	Drain Pan w/Pan Spray (Optional)
		1	Drain Pan w/Rear Outlet (Optional)
		1	Drain Pan w/Side Outlet (Optional)
		1	Drain Pan w/Dual Outlet (Optional)
10	20-25411-01-5	2	Prop Rod, Peel Chamber Door
11	30-38818-01-9	8	Hinge, Door
12	30-38998-02-5*	1	Panel, LH Drive Side 2920
	30-39270-02-5**	1	Panel, LH Drive Side 2920 1P
	30-39270-05-5**	1	Panel, LH Drive side 02920 1P W/Trapped Key
13	30-38998-01-5*	1	Panel, RH Drive Side 2920
	30-39270-02-5**	1	Panel, RH Drive Side 2920 1P
14	30-38997-01-5*	1	Panel, Inlet End 2920
	30-39267-01-5**	1	Panel, Inlet End 2920 1P
15	40-40036-05-1*	1	Bushing, 1.25B
	40-42294-08-1**	1	Bushing, QD #E 1.25B
16	40-42938-19-9*	1	Sprocket, Poly Chain
	See Section 1.2**	1	Sprocket, Eagle PD 140T
17	40-42937-15-9*	1	Drive Belt, Poly Chain GT
	40-43793-05-9**	1	Drive Belt, Eagle PD

18	See Section 1.2	1	Cover, Drive Belt
19	20-40903-01-1*	1	Bushing, 1.62B
	See Section 1.2**	1	Bushing, QD #SDS 1.62B
20	40-42938-18-9*	1	Sprocket, Poly Chain GT
	See Section 1.2**	1	Sprocket, Eagle PD 45T
21	See Section 1.2	1	10 HP Motor, (Voltage Optional)
22	30-38999-01-5	2	Panel, Lower Peel Chamber Door 2920
23	30-39000-01-5	4	Door Latch
24	40-43723-01-9	1	Bearing Support Block, Metric 2920
25	40-43734-01-9	7	Bearing Clamp Block
	40-44125-01-9	7	Bearing Clamp Block w/Finger
26	30-32171-01-9	7	Bearing Block Plug
27	50-59342-01-5	8	Bearing, Ball CYC, 1.19 SS
	40-40316-01-9	8	Bearing, RLR CYC BLK 1.19 Bore (PRE-2012)
28	20-24998-02-5	1	Handle, Discharge Gate
29	20-25455-01-5	1	Discharge Door Plate
30	20-25371-01-5	2	Hinge Pin
31	40-42477-02-5	2	Nozzle, Vee Jet
32	40-42195-03-5	2	Nozzle, Full Jet
33	20-25578-01-5*	1	Guard, Lower Drive Compartment
	20-26083-01-5**	1	Guard, Lower Drive Compartment 1P (1140 RPM DRIVE)
	20-26104-01-5**	1	Guard, Lower Drive Compartment 1P (1750 RPM DRIVE)
34	40-43594-01-5	1	Cover, Peel Chamber Top
35	50-59341-02-5	1	Inspection Door, 2920 Peel Chamber

* Serial numbers before #029220099XXXXX

**Serial numbers after #029220100XXXXX

5.2 02922 (IMPERIAL) PART IDENTIFICATION

NOTICE

** Part listed is for standard machine. See Section 1.2 Data Sheet and Section 6.0 for available options/alternate part numbers

REF · NO	PART NUMBER	NO. REQ.	DESCRIPTION
1	20-26062-02-5	1	Frame, 2922 Peeler
2	20-26066-04-5	1	Right Hand Splash Guard – 8 Roll
3	20-26066-03-5	1	Left Hand Splash Guard – 8 Roll
4	40-43770-01-9	1	Product Protector
5	30-39014-01-9	1	Product Retention Drape

6	30-38953-01-5	1	Clamp, Product Retention Drape
7	20-25404-01-5*	1	Pivot Plate, 2920 Motor Mount 256T
	20-26082-01-5**	1	Pivot Plate, 2920 Motor Mount 256T 1P
8	20-25704-01-5	4	Leveling Leg
9	See Section 1.2	1	Drain Pan Assy.- 2922 Dual outlet
		1	Drain Pan Assy.- 2922 Dual side outlet
		1	Drain Pan Assy.- 2922 Single outlet
		1	Drain Pan Assy.- 2922 Dual side outlet
10	20-25411-01-5	2	Prop Rod, Peel Chamber Door
11	30-38818-01-9	8	Hinge, Door
12	30-38998-02-5*	1	Panel, LH Drive Side 2920
	30-39270-02-5**	1	Panel, LH Drive Side 2920 1P
	30-39270-05-5**	1	Panel, LH Drive Side 2920 1P/ w Trapped Key
13	30-38998-01-5*	1	Panel, RH Drive Side 2920
	30-39270-01-5**	1	Panel, RH Drive Side 2920 1P
14	30-38997-01-5*	1	Panel, Inlet End 2920
	30-39267-01-5**	1	Panel, Inlet End 2920 1P
15	40-42294-08-1	1	Bushing, 1.25B
16	40-43794-06-9	1	Sprocket, Eagle PD 180T
17	40-43793-05-9	1	Belt, Eagle PD
18	20-25769-01-5	1	Cover, Drive Belt - 2922
19	See Section 1.2	1	Bushing, 1.62B
20	40-43794-05-9	1	Sprocket, Eagle PD 38T
21	See Section 1.2	1	15 HP Motor, (Voltage Optional)
22	30-39279-01-5	2	Panel, Lower Peel Chamber Door 2922
23	30-39000-01-5	4	Door Latch
24	40-43723-01-9	1	Bearing Support Block, Metric 2920
25	40-43734-01-9	7	Bearing Clamp Block
	40-44125-01-9	7	Bearing Clamp Block w/ Finger
26	30-32171-01-9	7	Bearing Block Plug
27	50-59342-01-5	8	Bearing, BALL CYC, 1.19 SS
	40-40316-01-9	8	Bearing, RLR CYC BLK 1.19 Bore (PRE – 2012)
28	20-24998-01-5	1	Handle, Discharge Gate
29	20-25455-01-5	1	Discharge Door Plate
30	20-25371-01-5	2	Hinge Pin
31	40-42477-02-5	2	Nozzle, Vee Jet
32	40-42195-03-5	3	Nozzle, Full Jet
33	20-25770-01-5*	1	Guard, Lower Drive Compartment
	20-26104-01-5**	1	Guard, Lower Drive Compartment 1P (1750 RPM DRIVE)
34	40-43741-02-5	1	Cover, Peel Chamber Top
35	50-59341-05-5	1	Inspection Door, 2922 Peel Chamber

* Serial numbers before #029220099XXXXX

**Serial numbers after #029220100XXXXX

5.3 02920 (METRIC) PART IDENTIFICATION

NOTICE

**** Part listed is for standard machine. See Section 1.2 Data Sheet and Section 6.0 for available options/alternate part numbers**

REF. NO	PART NUMBER	NO. REQ.	DESCRIPTION
1	20-26062-03-5	1	Frame, 2920 Peeler *METRIC FASTENERS*
2	20-28371-02-5	1	Right Hand Splash Guard – 8 Roll (METRIC)
3	20-28371-01-5	1	Left Hand Splash Guard – 8 Roll (METRIC)
4	40-43770-01-9	1	Product Protector
5	30-39014-01-9	1	Product Retention Drape
6	30-38953-01-5	1	Clamp, Product Retention Drape
7	20-26082-01-5	1	Pivot Plate, 2920 Motor Mount 256T 1P
8	20-24952-01-5	4	Leveling Leg
9	See Section 1.2	1	Drain Pan
9		1	Drain Pan w/Pan Spray (Optional)
9		1	Drain Pan w/Dual Outlet (Optional)
10	20-25411-01-5	2	Prop Rod, Peel Chamber Door
11	30-38818-01-9	8	Hinge, Door
12	30-39270-02-5	1	Panel, LH Drive Side 2920 1P
13	30-39270-01-5	1	Panel, RLH Drive Side 2920 1P
14	30-39267-01-5	1	Panel, Inlet End 2920 1P
15	40-42294-08-1	1	Bushing, QD #E 1.25B
16	See Section 1.2	1	Sprocket, Eagle PD 140T
17	40-43793-05-9	1	Drive Belt, Eagle PD
18	See Section 1.2	1	Cover, Drive Belt
19	See Section 1.2	1	Bushing, QD #SDS 1.62B
20	See Section 1.2	1	Sprocket, Eagle PD 45T
21	See Section 1.2	1	10 HP Motor, (Voltage Optional)
22	30-38999-01-5	2	Panel, Lower Peel Chamber Door 2920
23	30-39000-01-5	4	Door Latch
24	30-40432-01-9	1	Bearing Support Block, Metric Fasteners
25	40-43734-01-9	7	Bearing Clamp Block
	40-44125-01-9	7	Bearing Clamp Block w/Finger
26	30-32171-02-9	7	Bearing Block Plug – Metric M8 -1.25 (BRASS)
27	50-59342-01-5	8	BEARING, BALL CYC, 1.19 SS
28	20-24998-02-5	1	Handle, Discharge Gate
29	20-28372-01-5	1	Discharge Door Plate (METRIC FASTENERS)
30	20-25371-01-5	2	Hinge Pin

31	40-42477-02-5	2	Nozzle, Vee Jet
32	40-42195-03-5	2	Nozzle, Full Jet
33	20-26083-01-5	1	Guard, Lower Drive Compartment 1P
34	40-43594-01-5	1	Cover, Peel Chamber Top
35	50-59341-02-5	1	Inspection Door, 2920 Peel Chamber

5.4 02922 (METRIC) PART IDENTIFICATION

NOTICE

**** Part listed is for standard machine. See Section 1.2 Data Sheet and Section 6.0 for available options/alternate part numbers**

REF. NO	PART NUMBER	NO. REQ.	DESCRIPTION
1	20-26062-02-5	1	Frame, 2922 Peeler
2	20-28371-04-5	1	Right Hand Splash Guard – 8 Roll (METRIC)
3	20-28371-03-5	1	Left Hand Splash Guard – 8 Roll (METRIC)
4	40-43770-01-9	1	Product Protector
5	30-39014-01-9	1	Product Retention Drape
6	30-38953-01-5	1	Clamp, Product Retention Drape
7	20-26082-01-5	1	Pivot Plate, 2920 Motor Mount 256T 1P
8	20-25704-01-5	4	Leveling Leg
9	See Section 1.2	1	Drain Pan - 2922 dual outlet
10	20-25411-01-5	2	Prop Rod, Peel Chamber Door
11	30-38818-01-9	8	Hinge, Door
12	30-39270-02-5	1	Panel, LH Drive Side 2920 1P
	30-39270-05-5	1	Panel, LH Drive Side 2920 1P W/ Trapped Key
13	30-39270-01-5	1	Panel, RH Drive Side 2920 1P
14	30-39267-01-5	1	Panel, Inlet End 2920 1P
15	40-42294-08-1	1	Bushing, 1.25B
16	See Section 1.2	1	Sprocket, Eagle PD 180T
17	40-43793-05-9	1	Belt, Eagle PD
18	20-25769-01-5	1	Cover, Drive Belt - 2922
19	See Section 1.2	1	Bushing, QD #SDS 42MM BORE
20	40-43794-05-9	1	Sprocket, Eagle PD 38T
21	See Section 1.2	1	15 HP Motor, (Voltage Optional)
22	30-39279-01-5	2	Panel, Lower Peel Chamber Door 2922
23	30-39000-01-5	4	Door Latch
24	30-40432-01-9	1	Bearing Support Block, Metric Fasteners
25	40-43734-01-9	7	Bearing Clamp Block
	40-44125-01-9	7	Bearing Clamp Block w/ Finger
26	30-32171-02-9	7	Bearing Block Plug – Metric M8 -1.25 (BRASS)

27	50-59342-01-5	8	Bearing, BALL CYC, 1.19 SS
28	20-24998-01-5	1	Handle, Discharge Gate
29	20-28372-01-5	1	Discharge Door Plate (METRIC FASTENERS)
30	20-25371-01-5	2	Hinge Pin
31	40-42477-02-5	2	Nozzle, Vee Jet
32	40-42195-03-5	3	Nozzle, Full Jet
33	20-26104-01-5	1	Guard, Lower Drive Compartment 1P
34	40-43741-02-5	1	Cover, Peel Chamber Top
35	50-59341-05-5	1	Inspection Door, 2922 Peel Chamber

5.5 PEELING ROLLS

5.5.1 02920 PEELER ROLLS

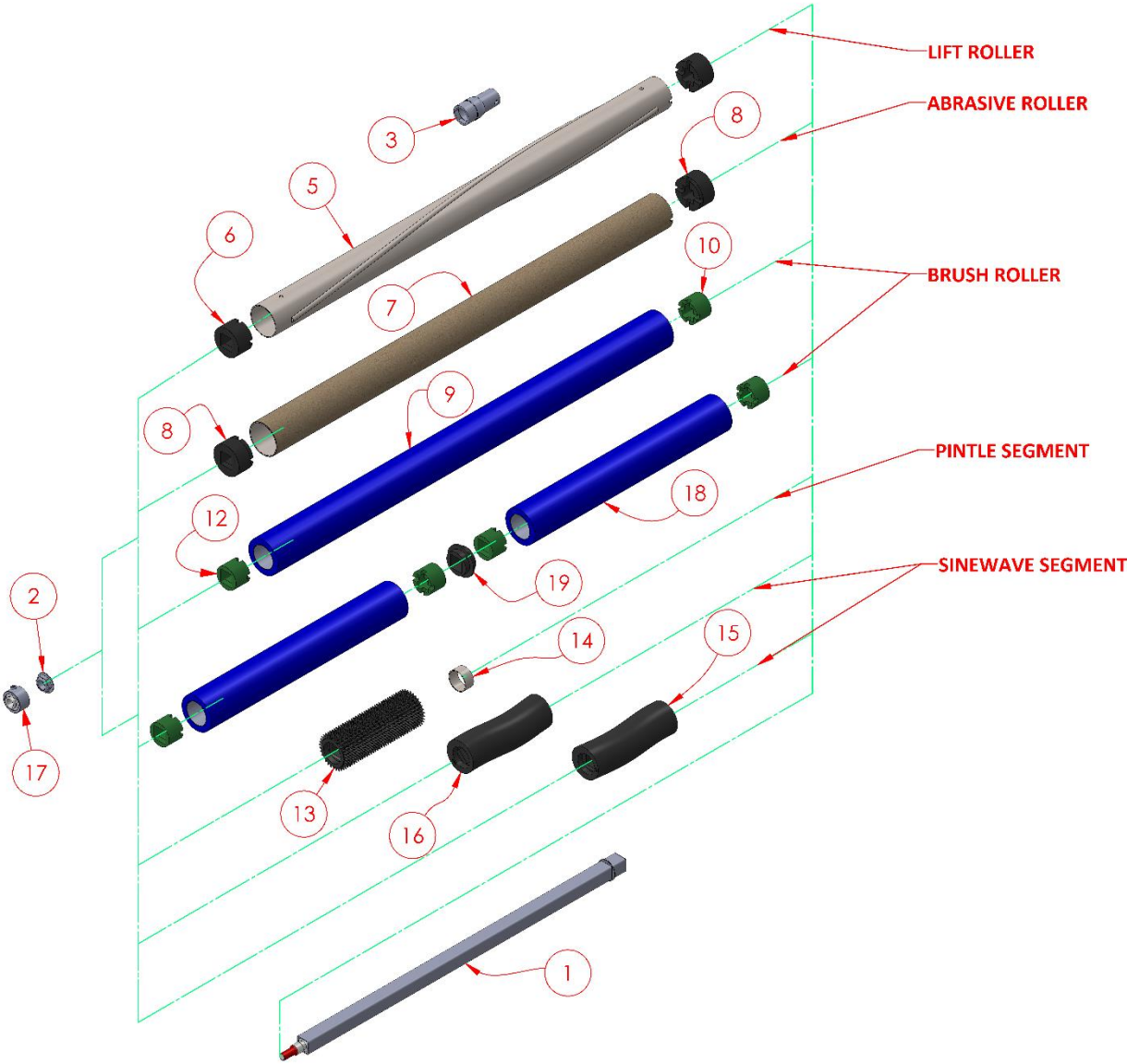

Ref. No.	Part Number	Description
1	20-20779-01-5	SHAFT, Peeling Roll
2	20-20249-01-1	NUT ASSEMBLY
3	30-31126-01-9	SOCKET, Nut Assembly
5	20-20750-01-5	ROLL, Lift - LH - 4.50 OD
	20-29336-01-5	ROLL, Lift - Abr - #10 Grit
	20-29336-02-5	ROLL, Lift - Abr - #20 Grit
	20-29336-03-5	ROLL, Lift - Abr - #36 Grit
	20-29337-01-5	ROLL, Lift - Abr - .50- #10 & .50- #20 Grit
6	30-32485-01-9	ROLL, Lift End Fixture - 2 / Roll
7	20-29252-02-1	ROLL, Abr - .50- #10 & .50- #20 Grit - 4.75 OD
	20-29252-04-1	ROLL, Abr - .75- #10 & .25- #20 Grit - 4.75 OD
	20-29316-02-1	ROLL, Abr - #10 - 4.75 OD
	20-29316-01-1	ROLL, Abr - #20 - 4.75 OD
	20-29207-01-1	ROLL, Abr - #20 Grit - 5.00 OD
	20-29207-05-1	ROLL, Abr - #30 Grit - 5.00 OD
	20-29207-02-1	ROLL, Abr - #36 Grit - 5.00 OD
	20-29207-03-1	ROLL, Abr - #60 Grit - 5.00 OD
	20-29207-06-1	ROLL, Abr - #80 Grit - 5.00 OD
20-29319-01-1	ROLL, Abr - .67-#20 Grit & .33-#36 Grit - 5.00 OD	
8	40-41129-01-9	ROLL, Abr End Fixture - 2 /Roll
9	40-41329-02-9	BRUSH, .014 – Black/2 Blue stripes
	40-43534-08-9	BRUSH, .026 – Blue/2 Black stripes
	40-43738-04-9	BRUSH, .010 – Black/1 Blue stripes
	40-40261-15-9	BRUSH, NYLN BLK 022/ 3 BLUE STRIPES
	40-40260-03-9	BRUSH, .045 – Blue/4 Black stripes
	40-40347-14-9	BRUSH, Nylon - .022/.036 60/40
	40-43034-01-9	BRUSH, Abr Tynex A - .022 - #120 Epoxy Filled
10	40-40259-02-9	BRUSH, End Fixture - 2 / Roll
11	40-41566-09-9	BRUSH, .022 - Random Trim - 3.12 ID
	40-42699-01-9	BRUSH, Abr Tynex A - .040 - #120 - 3.12 ID
12	30-33740-01-9	BRUSH, 3.12 ID End Fixture -
13	40-40369-01-9	SEGMENT, Pintle Straight Rbr -
	40-40369-02-9	SEGMENT, Pintle Straight Ntrl -
	40-40242-01-9	SEGMENT, Pintle Sine RH Rbr -
14	30-32118-01-5	SPACER – Pintle 3.00” O.D. X 1.44
15	30-31990-01-9	SEGMENT, Abr Sine - LH - #10
	30-31156-01-9	SEGMENT, Abr Sine - LH - #20
	30-33658-01-9	SEGMENT, Abr Sine - LH - #36
16	30-31991-01-9	SEGMENT, Abr Sine - RH - #10
	30-31157-01-9	SEGMENT, Abr Sine - RH - #20
	30-33659-01-9	SEGMENT, Abr Sine - RH - #36
17	50-59342-01-5	BEARING, BALL CYC, 1.19 SS

	40-40316-01-9	BEARING, RLR CYC BLK 1.19 Bore (PRE 2012)
18	40-40260-04-9	BRUSH, NYLN BLU/BLK 045 (34.75" LG)
	40-40261-16-9	BRUSH, NYLN BLK/BLU 022 (34.75" LG)
	40-41566-03-9	BRUSH, NYLN COM/BLK 022 (34.75" LG)
	40-43534-10-9	BRUSH, NYLN BLU/BLK 026 (34.75" LG)
	40-43813-02-9	BRUSH, NYLN BLK/NAT 014 (34.75" LG)
	40-43926-02-9	BRUSH, NYLN BLK/BLU 060 (34.75" LG)
	40-43993-01-9	BRUSH, DUAL FILAMENT GREEN (34.75" LG)
19	40-43924-01-9	SPACER, BRUSH CENTER ADAPTER

5.5.2 02922 PEELER ROLLS

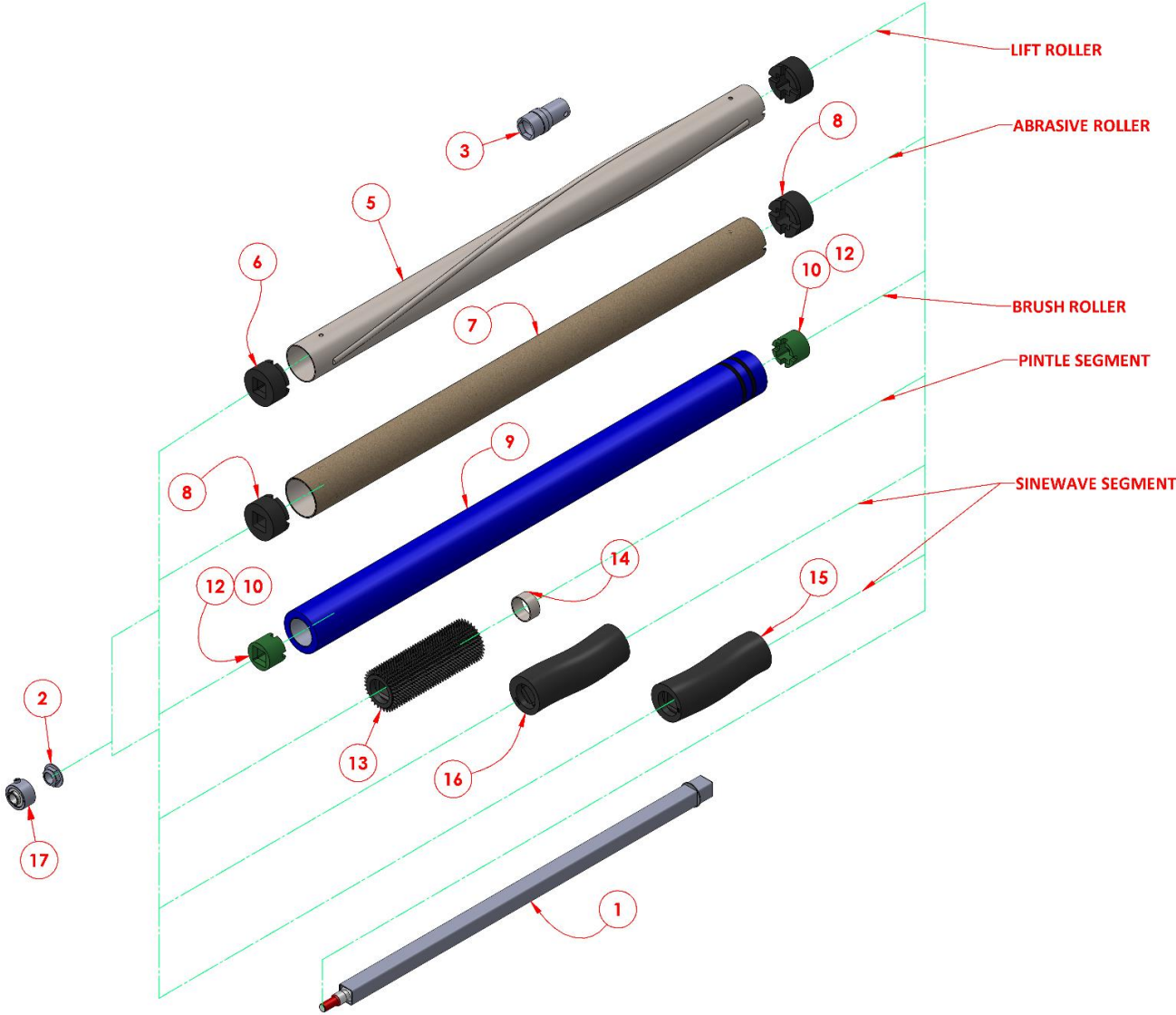

Ref. No.	Part Number	Description
1	20-20779-04-5	SHAFT, Peeling Roll
2	20-20249-01-1	NUT ASSEMBLY
3	30-31126-01-9	SOCKET, Nut Assembly
5	20-20750-04-5	ROLL, Smooth – 97.75
6	30-32485-01-9	ROLL, Lift End Fixture - 2 / Roll
7	20-29316-03-1	ROLL, ABR SV 4.75 OD #10 GRIT 97.75"
	20-29207-10-1	ROLL, ABR SV 5.00 OD #20 GRIT 97.75"
	20-29207-13-1	ROLL, ABR SV 5.00 OD #36 GRIT 97.75"
	20-29252-09-1	ROLL, ABR SV 5.00 OD 1/2-#10 1/2-#20
	20-29252-08-1	ROLL, ABR SV 5.00 OD 1/2-#20 1/2-#36
8	40-41129-01-9	ROLL, Abr End Fixture - 2 / Roll
9	40-43534-07-9	BRUSH, .026 – Blue w/2 Dark Blue stripes
	40-40347-13-9	BRUSH, Nylon - .022/.036 60/40
	40-43738-05-9	BRUSH, Nylon - .010 Blk/Blu
10	40-40259-02-9	BRUSH, End Fixture - 2 / Roll
11	40-41566-08-9	BRUSH, .022 - Random Trim - 3.12 ID 97.75
12	30-33740-01-9	BRUSH, 3.12 ID End Fixture -
13	40-40369-01-9	SEGMENT, Pintle Straight Rbr -
	40-40369-02-9	SEGMENT, Pintle Straight Ntrl -
	40-40242-01-9	SEGMENT, Pintle Sine RH Rbr -
14	30-32118-01-5	SPACER – Pintle 3.00" O.D. X 1.44
15	30-31990-01-9	SEGMENT, Abr Sine - LH - #10
	30-31156-01-9	SEGMENT, Abr Sine - LH - #20
	30-33658-01-9	SEGMENT, Abr Sine - LH - #36
16	30-31991-01-9	SEGMENT, Abr Sine - RH - #10
	30-31157-01-9	SEGMENT, Abr Sine - RH - #20
	30-33659-01-9	SEGMENT, Abr Sine - RH - #36
17	50-59342-01-5	BEARING, BALL CYC, 1.19 SS
	40-40316-01-9	BEARING, RLR CYC BLK 1.19 Bore (PRE-2012)

5.5.3 COMMON BRUSH PART NUMBERS

0.010 NYLON BRUSH

40-43738-04-9 – 69.75" LG
40-43738-05-9 – 97.75" LG

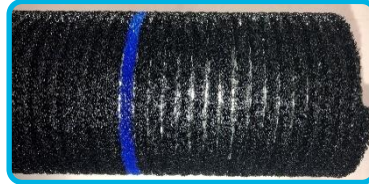

0.014 NYLON BRUSH

40-41329-05-9 – 69.75" LG
40-41329-07-9 – 97.75" LG



0.022 NYLON BRUSH

40-40261-15-9 – 69.75" LG
40-40261-16-9 – 34.75" LG
40-40261-17-9 – 97.75" LG
40-40261-19-9 – 62.75" LG



**0.022 RANDOM TRIM
NYLON BRUSH**

40-41566-09-9 – 69.75" LG



0.026 NYLON BRUSH

40-43534-07-9 – 97.75" LG
40-43534-08-9 – 69.75" LG
40-43534-10-9 – 34.75" LG
40-43534-11-9 – 62.75" LG

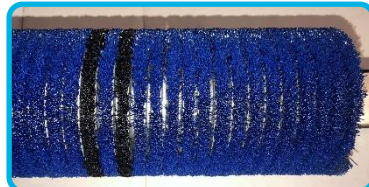

0.045 NYLON BRUSH

40-40260-03-9 – 69.75" LG
40-40260-05-9 – 97.75" LG

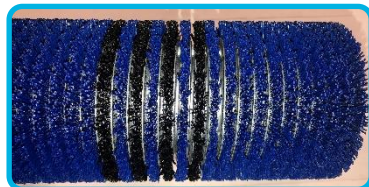

0.022/0.036 NYLON BRUSH

40-40347-13-9 – 97.75" LG
40-40347-14-9 – 69.75" LG
40-40347-17-9 – 62.75" LG
40-43993-01-9 – 34.75" LG

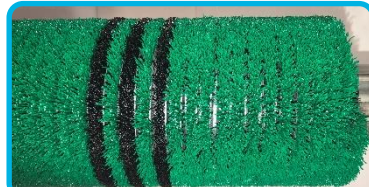

5.6 DRIVE CASE (IMPERIAL PARTS, STANDARD)

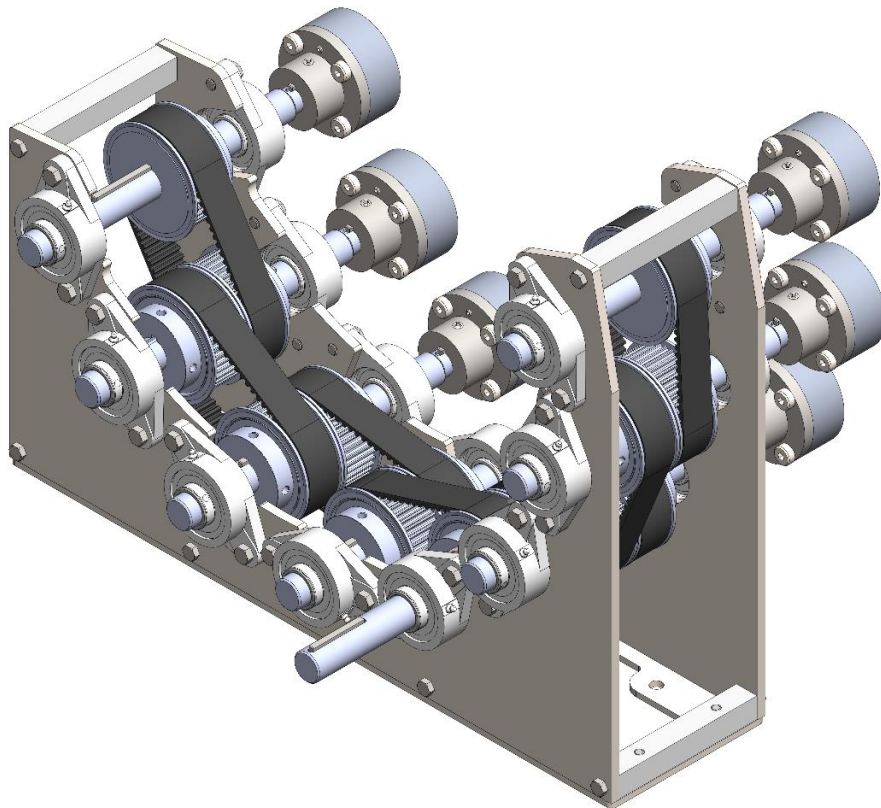

59330

Ref. No.	Part Number	No. Req.	Description
1	30-39028-01-5	2	BEARING PLATE, METRIC DRIVE
2	30-38949-01-5	1	BASE, STEEL DRIVE CASE
3	30-31489-01-5	4	CONNECTOR, 6.75
4	30-31489-02-5	2	CONNECTOR, 6.75 2 HOLES
5	30-38947-03-5	1	DRIVE SHAFT, 2920, Position #4
	30-38947-03-5	1	DRIVE SHAFT, 2922, Position #5
6	30-38947-02-5	7	ROLL SHAFT, STEEL DRIVE CASE
7	30-34185-07-5	9	KEY, .25 SQ. x 1.50 LG SS
8	30-34185-29-5	8	KEY, .25 SQ. x 5.25 LG SS
9	40-43731-01-9	14	SPROCKET, POLY CHAIN GT
10	40-42937-13-9	7	BELT, POLY CHAIN GT
11	40-40917-04-9	16	BEARING, BALL FLANGE 1.25B
12	60-60660-01-5	8	COUPLER, QUICK CHANGE ASSY, 1.00 B
	40-40236-01-9	8	COUPLER, URETHANE 1.00B (pre 2012)
13	48-48080-01-5	32	SCREW, .44 – 20 x 1.00 SS
14	48-48050-01-5	20	SCREW, .38 – 16 x 1.25 HEX SS

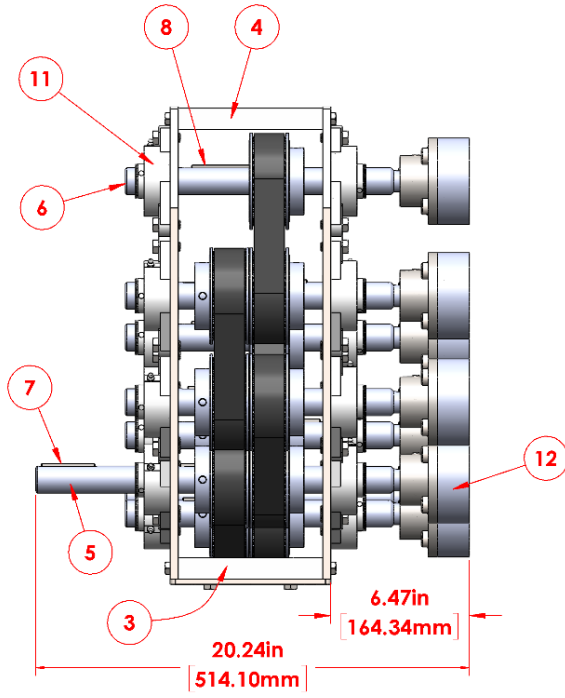
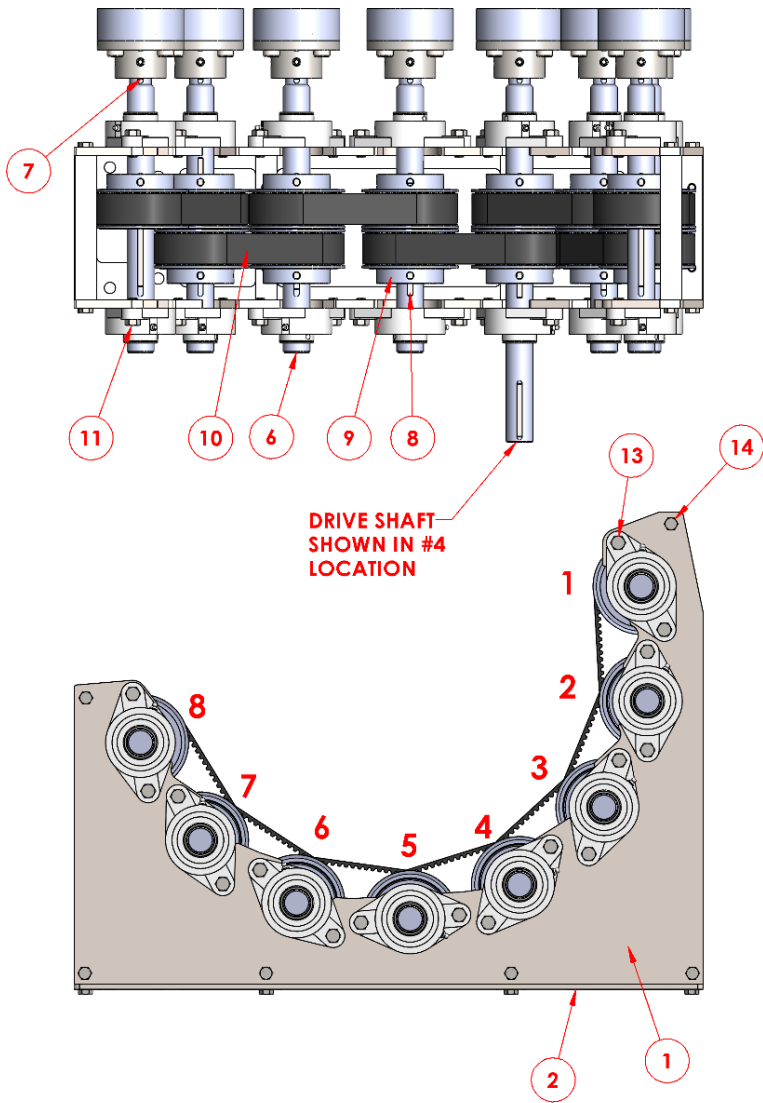

To feed our growing world - Together

300 Industrial Parkway, Creston, IA 50801, USA
 Phone: +1 740-201-0004
 vanmark.com

02920 / 02922 PEELER MANUAL
 REV. A 2020

5.7 DRIVE CASE (METRIC PARTS)

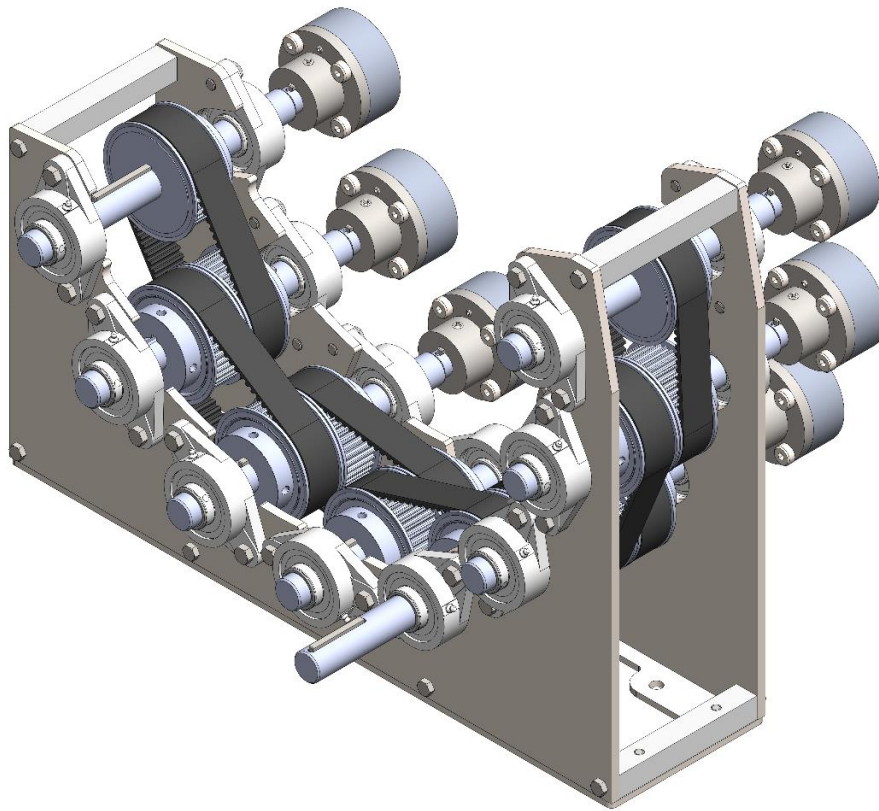

59330

Ref. No.	Part Number	No. Req.	Description
1	30-40431-01-5	2	BEARING PLATE, METRIC DRIVE (METRIC FASTENERS)
2	30-38949-01-5	1	BASE, STEEL DRIVE CASE
3	30-31489-03-5	4	CONNECTOR, 6.75 - M10-1.50 THRD
4	30-31489-04-5	2	CONNECTOR, 6.75 2 HOLES - M10-1.50 THRD
5	30-38947-03-5	1	DRIVE SHAFT, 2920, Position #4
	30-38947-03-5	1	DRIVE SHAFT, 2922, Position #5
6	30-38947-02-5	7	ROLL SHAFT, STEEL DRIVE CASE
7	30-34185-07-5	9	KEY, .25" SQ. x 1.50" LG SS
8	30-34185-29-5	8	KEY, .25" SQ. x 5.25" LG SS
9	40-43731-01-9	14	SPROCKET, POLY CHAIN GT
10	40-42937-13-9	7	BELT, POLY CHAIN GT
11	50-59599-01-9	16	BEARING, BALL FLANGE 1.25B W/METRIC BUSHINGS
12	60-60660-01-5	8	COUPLER, QUICK CHANGE ASSY, 1.00" B
	40-40236-01-9	8	COUPLER, URETHANE 1.00" B (pre 2012)
13	48-48433-25-5	32	SCR, M10-1.50 X 25.00 HEX SS
14	48-48433-25-5	20	SCR, M10-1.50 X 25.00 HEX SS

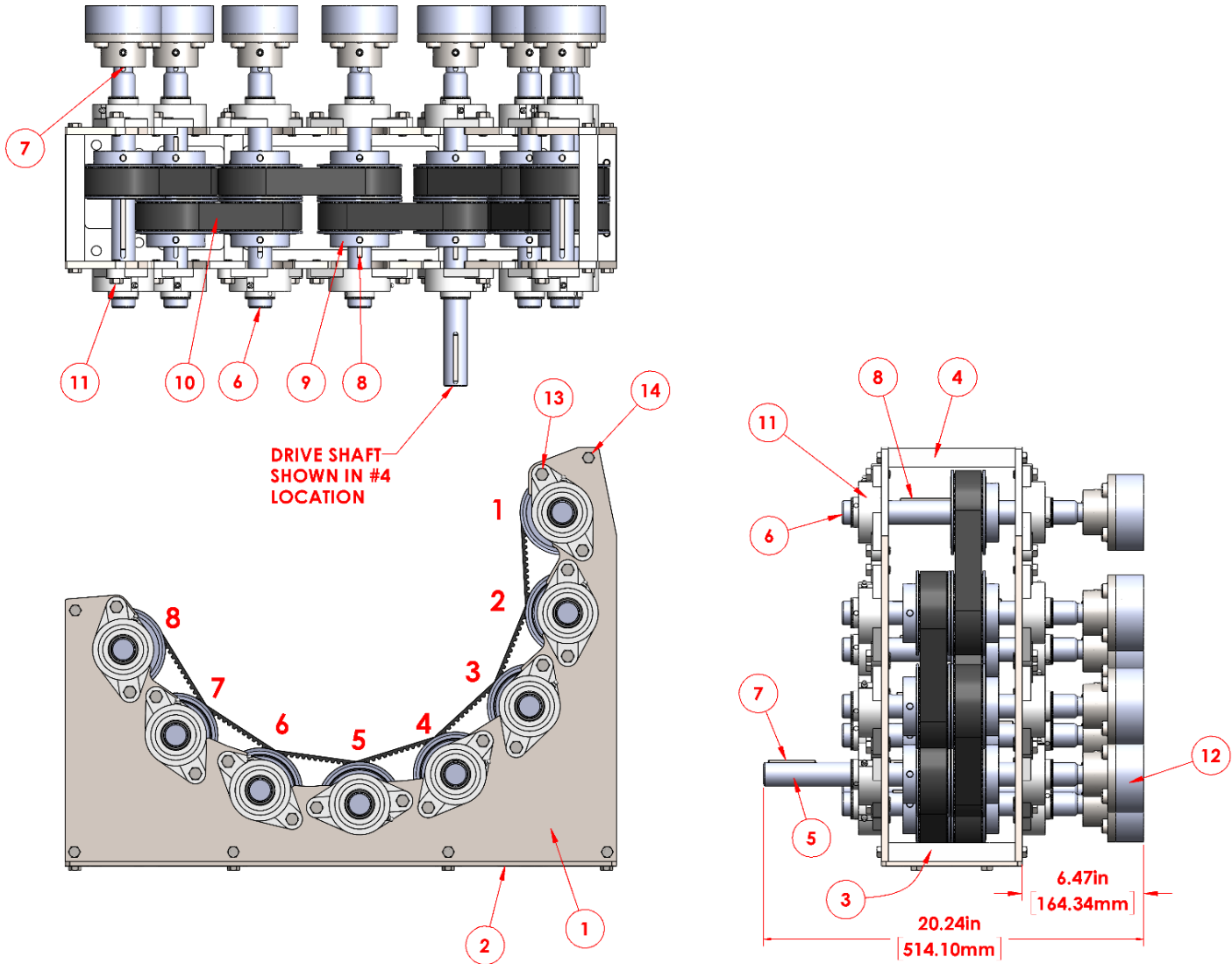

To feed our growing world - Together

300 Industrial Parkway, Creston, IA 50801, USA
 Phone: +1 740-201-0004
 vanmark.com

02920 / 02922 PEELER MANUAL
 REV. A 2020

6.0 EQUIPMENT OPTIONS

NOTICE

Refer to Section 1.2 Data Sheet which identifies which options your machine was originally manufactured with and the corresponding machine serial number. This is critical for selecting the proper components for your machine.

6.1 AUTOMATIC LUBRICATION



6.1.1 START-UP:

The optional Auto-Lube System is designed to provide proper regular greasing of the discharge end bearings on the peeling rolls. This system has been proven to provide increased life of the discharge bearings. The lube system only cycles when the machine is running to avoid unnecessary use of grease.

The pump is available in both 24- and 120-Volt configurations so always make sure to check the Data Sheet, drawing, or the schematic on the inside door of the electrical enclosure to determine the proper

supply voltage. Verify the pump rotor is rotating the correct direction with the direction arrow located on the pump body.

NOTICE

Refer to Section 8.6 for wiring details for the Auto Lube System. Applying incorrect voltage can damage the unit and must be verified prior to applying power. Refer to the machine approval drawing, P&ID, Electrical Box on the machine, or Data Sheet for proper voltage.

Open the electrical enclosure and locate the Auto Lube terminal block. This is illustrated in Section 8.2 & 8.6 of this manual. The Auto-Lube will need a continuous supply of power through the fused terminal. The machine comes equipped with a jumper wire between terminals 1 and 2. If left in place, the system can operate but the built-in timer will reset each time it's powered off.

Vanmark recommends replacing the jumper between terminals 1 and 2 with a "DRY" contact switch from the main roll drive motor VFD. When the peeling rolls are ON, this contact should be closed enabling the lube system. When the peeling rolls are OFF, this contact should be open disabling the lube system. When the peeling rolls are ON, this contact will be closed enabling the lube system. This will allow the timer to maintain its progress in the lube cycle when the machine is stopped.

6.1.2 OPERATION:

Each time the machine contact is switched on, a functional check of the drive motor and signal lamp takes place automatically. During the functional check the motor is switched on for 0.1 seconds (the stirring paddle slightly rotates) and the signal lamp lights up for 2 seconds. If there is a fault, the signal lamp flashes (see Section 6.1.4 Troubleshooting). The control unit automatically controls the proceeding of the pause and operating times of the centralized lubrication pump. A lubrication cycle consists of one pause time and one operating time. Once the pause time has elapsed, the operating time starts running. The lubrication cycle is repeated permanently after the machine has been put into operation. During the operating time the pump element delivers the lubricant to the lubrication points via progressive metering devices.

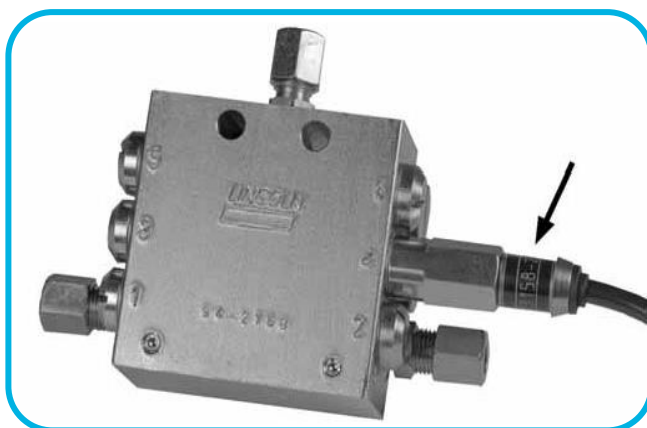

A piston detector that has been installed on a metering block instead of a piston closure plug, monitors and brings the operating time to a close after all the pistons of this metering block have dispensed their lubricant quantity.

A fixed monitoring time of maximum 5 minutes runs in parallel to the operating time. If there is no switching off signal from the piston detector to the printed circuit board within 5 minutes, a fault signal will occur.

Additional lubrication cycles are possible at any time by actuating the pushbutton on the pump, or the outside of the electrical enclosure.

Setting of the pause time:

The pause time can be set with the **blue rotary switch** to 15 stages.



Time Setting:

To set the pause or operating time, remove the cover on the pump housing.

Important:

After having set the pause time or operating time, screw the cover on the pump housing again.

If the housing is not closed, water may enter, damaging components.

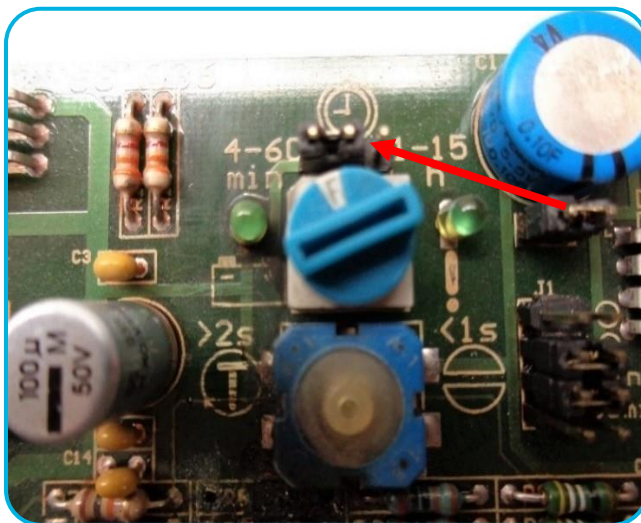

The jumper above the blue rotary switch is to set the desired time range (4-60 minutes or 1-15 hours). Using tweezers or pointed pliers, the jumper can be pulled outwards to remove and change positions.

The jumper is set to 4-60 min. from factory (as shown in picture.)

Switch position	0/1	2	3	4	5	6	7	8	9	A	B	C	D	E	F
Minutes	4	8	12	16	20	24	28	32	36	40	44	48	52	56	60
Hours	1	2	3	4	5	6	7	8	9	10	11	12	13	14	15

Discharge Bearings (8)	Jumper Position	Blue rotary switch position
50-59342-01-5 (STD) Stainless Housing	Min (4-60)	F (60 min)
40-40316-01-9 (Mild Steel Housing)	Min (4-60)	6 (24 min)

6.1.3 MAINTENANCE:

The maintenance is essentially limited to refilling the reservoir with clean lubricant in good time. However, check regularly whether the lubricant is really dispensed to all the lubrication points. Also check the main lines and lubricant feed lines for damage and replace them, if necessary. Whenever work is done on the centralized lubrication system, particular attention should be paid to absolute cleanliness. **Dirt in the system will cause problems.**

For cleaning the system use benzene or petroleum; do **NOT** use tri-, perchloroethylene or similar solvents, or polar organic solvents such as alcohol, methylacohol, acetone or similar.

To Fill the Reservoir:

The pump will come pre-filled on a new machine but will require re-filling after the grease is used. Fill the reservoir with the recommended NLGI food grade grease. Vanmark recommends High Performance Lubricants, HP Clear Food Grade Grease, NLGI Grade 0. Filling the reservoir should be done using a lever action cartridge grease gun or an electric grease gun. It is not recommended to use a pneumatic grease gun. Always use grease from a suitable dispenser with a sealed grease container. Contaminated grease will shorten the life of the pump and could prevent proper operation.

CAUTION

Risk of bursting the reservoir if it is overfilled. When filling the reservoir by means of pumps with a large delivery volume, do NOT exceed the max filling mark.

1. Locate the Reservoir Filling fitting, located above and to the right of the timer window
2. Using a lever type or electric grease gun, fill the reservoir with the proper NLGI grade 0 food grade grease
3. DO NOT exceed the max filling mark on the reservoir

6.1.4 TROUBLESHOOTING

If a fault is indicated, begin reviewing the system for proper operation. Note, dirt in the system will cause problems so use care when disassembling any grease connections to prevent contamination:

1. Start by checking the reservoir ensuring grease is available, and the timer setting is correct.
2. Verify the power is properly connected with the correct voltage.
3. Verify proper rotation direction of the stirring paddle with the direction arrow located on the reservoir.
4. Visually inspect the pin on the metering block as it should move in and out during a lubrication cycle. If it does not, this indicates grease is not being dispensed properly. Try manually pumping grease through the Reservoir Filling fitting on the pump to prime the pump
5. If grease is still not properly being dispensed at the metering block, disconnect the SS tubing from the metering block that carries grease from the pump. Manually pump grease in the Manual Lubrication fitting located at the pump to clear the grease line pushing any debris or air bubbles out. Then re-connect the hard line to the metering block and perform another test cycle.
6. If grease is properly pumping but the system is faulting, inspect the piston detector for proper operation

Pump Components

1. Grease reservoir
2. Pump Element
3. Pressure Relief Valve
4. Manual Lubrication Fitting
5. Connector, piston detector
6. Reservoir Filling Fitting
7. Printed Circuit Board, mounted
8. Connector/Plug, Power supply
9. Connector/Plug, illuminated push button
10. Return Line Connection (optional)

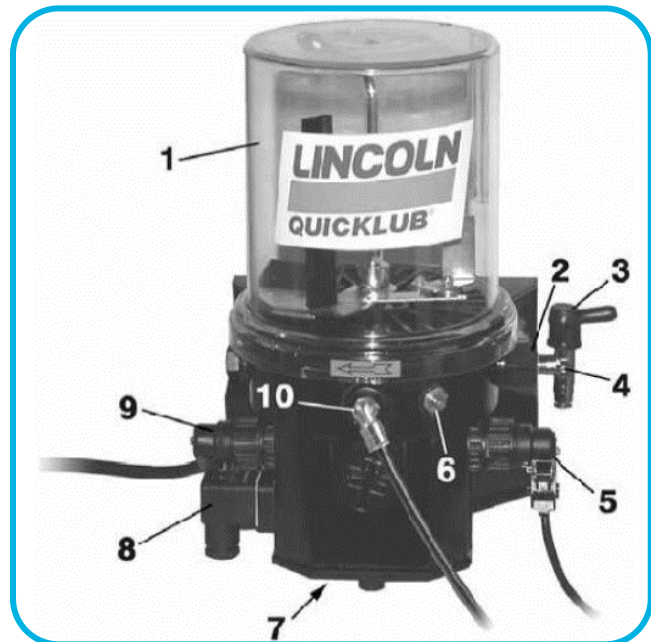

6.1.5 AUTO LUBE PARTS LIST

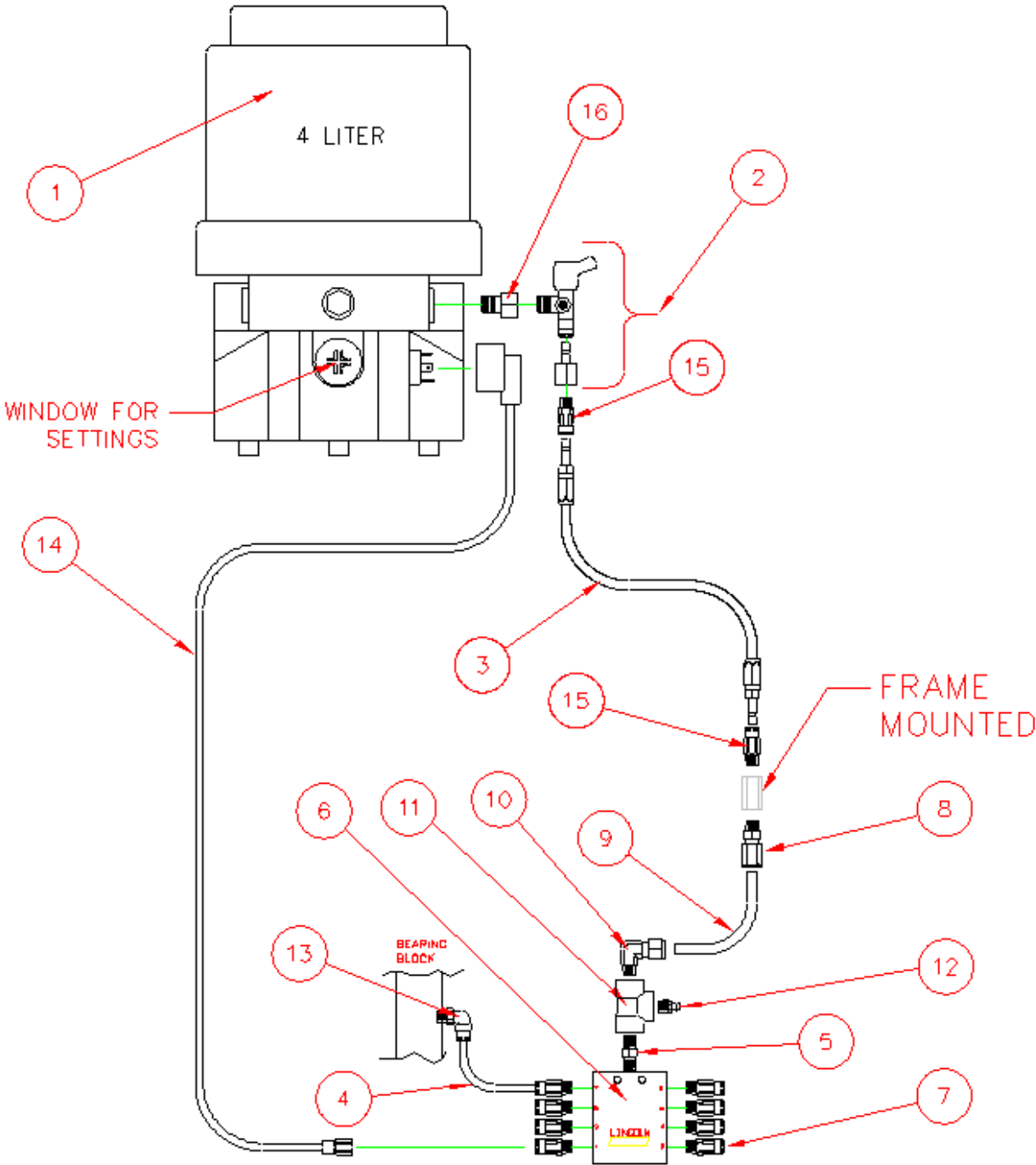

60655

Ref. No.	Part No.	No. Req.	Description
1	40-43832-01-9	1	Pump, 4L, Grease 120VAC
	30-39171-01-9	1	Pump, 4L, Grease 24VDC
2	40-43835-01-9	1	Pressure Relief Valve, .125
3	50-59345-07-9	1	Hose Assy. High Pressure (26.0" LG)
4	40-43836-02-9	13	Tubing, .25 O.D. Nylon
5	40-40334-01-5	1	Nipple, Hyd. .125 SS
6	40-43838-02-9	1	Divider, 8 outlet S.S.
7	40-43840-01-9	8	Fitting, Straight W/Check
8	40-41462-01-5	1	Connector, FRLS .312T X .125 MPT S.S.
9	40-47211-01-5	7.5	Tubing, Round .31 x 22GA 304SS ASTM 249
10	40-43841-01-9	1	Elbow, FLRLS 90 .31 T X .125 MPT
11	40-43849-01-5	1	Tee, Hyd. .125 Street
12	40-40455-01-1	2	Zerk, .125 MPT straight
13	40-43842-01-5	8	Elbow, S.S., 90 .25 T X .125 MPT Swivel
	40-43842-01-9	8	Elbow, Brass., 90 .25 T X .125 MPT Swivel
14	40-43845-01-9	1	Proxy Switch W/Cable 3M (9.8')
	40-43845-02-9	1	Proxy Switch W/Cable 7M (23.0')
15	40-43837-01-5	2	Connector, S.S. 0.25 T X 0.12 MPT
	40-43837-01-9	2	Connector, Brass, 0.25 T X 0.12 MPT
16	40-44041-01-9	1	Adapter, Outlet Pressure Relief

6.2 DISCHARGE OPTIONS

6.2.1 NATURAL FLOW GATE DISCHARGE (IMPERIAL)

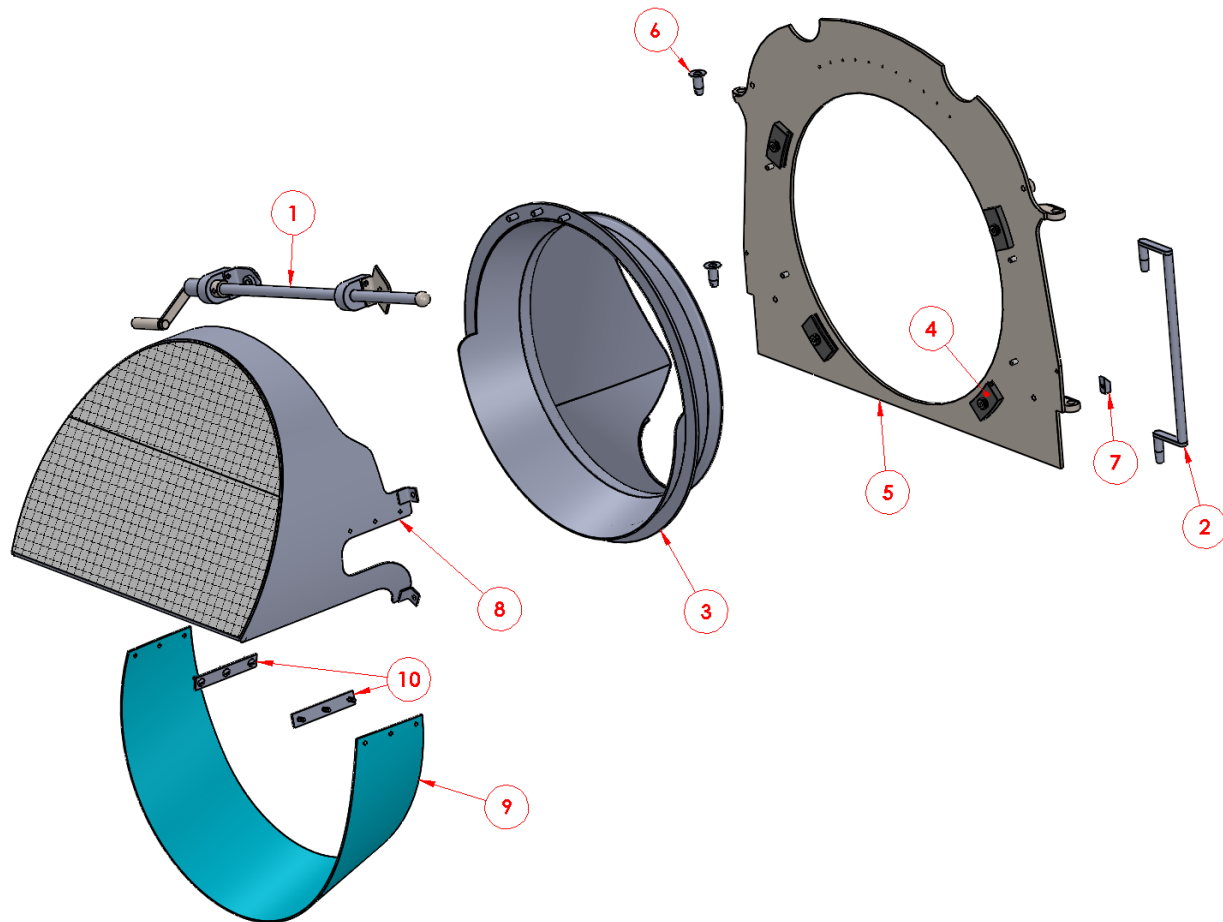

Ref. No.	Part Number	No. Req.	Description
1	50-59316-01-5	1	Handle Assembly, Natural Flow Gate
2	20-24998-02-5	1	Handle, Dual Swing Door
3	20-25398-01-5	1	Gate, Natural Flow
4	30-38939-01-9	4	Guide, Natural Flow Gate rotation
5	20-25455-01-5	1	Door, Dual Swing
6	20-25371-01-5	2	Pin, Hinge
7	30-38908-01-5	1	Stop Tab, Gate Handle
8	20-25399-01-5	1	Shroud, Natural Flow Gate
9	30-38993-01-9	1	Chute Extension, Natural Flow (Volta)
10	20-25367-01-5	2	Clamp, Chute Extension (Volta)

6.2.2 NATURAL FLOW GATE DISCHARGE (METRIC)

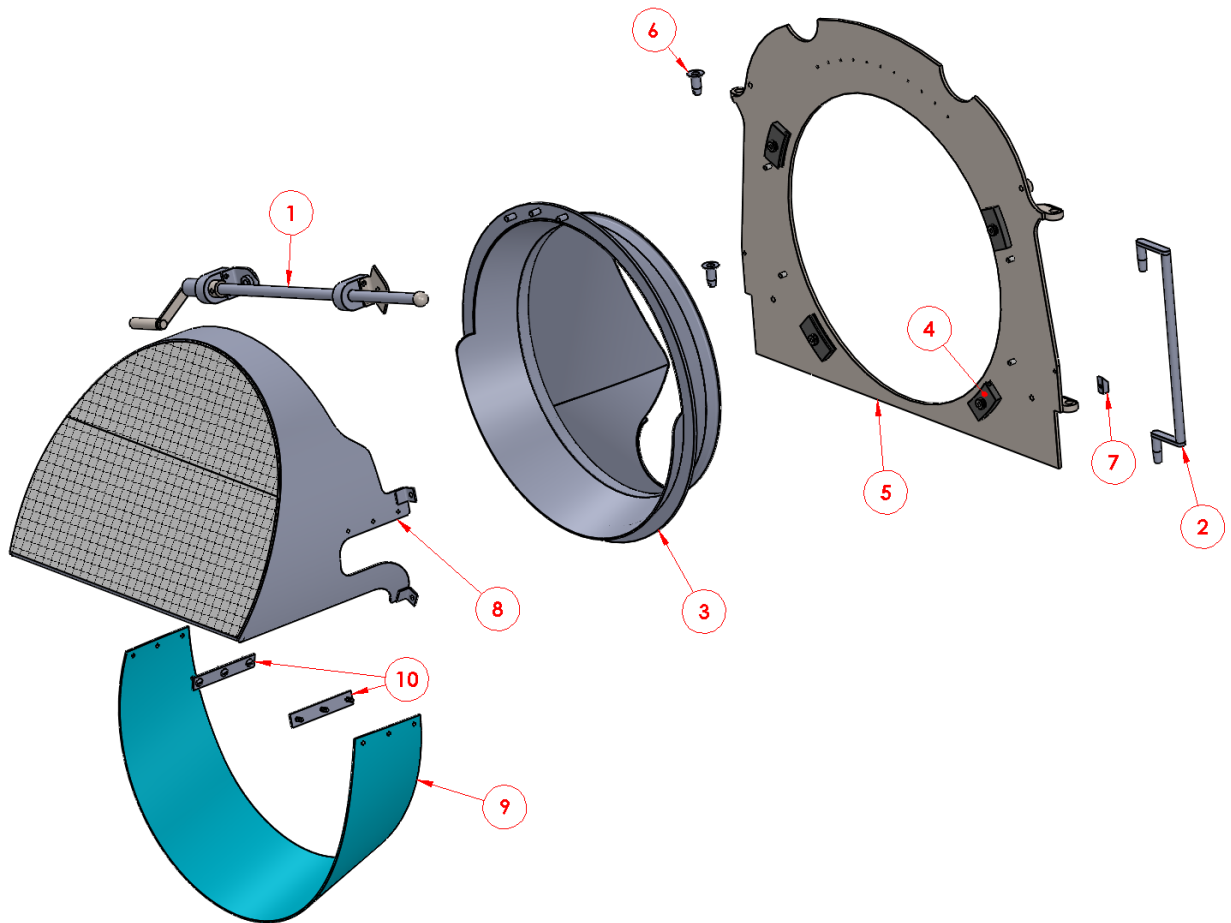

Ref. No.	Part Number	No. Req.	Description
1	50-59316-01-5	1	Handle Assembly, Natural Flow Gate
2	20-24998-02-5	1	Handle, Dual Swing Door
3	20-25398-02-5	1	Gate, Natural Flow Skin-on (METRIC)
4	30-38939-01-9	4	Guide, Natural Flow Gate rotation
5	20-28372-01-5	1	Discharge Door Plate (METRIC FASTENERS)
6	20-25371-01-5	2	Pin, Hinge
7	30-38908-01-5	1	Stop Tab, Gate Handle
8	20-25399-01-5	1	Shroud, Natural Flow Gate
9	30-38993-01-9	1	Chute Extension, Natural Flow (Volta)
10	20-25367-02-5	2	Clamp, Chute Extension (METRIC)

6.2.3 HANDLE ASSEMBLY, NATURAL FLOW GATE

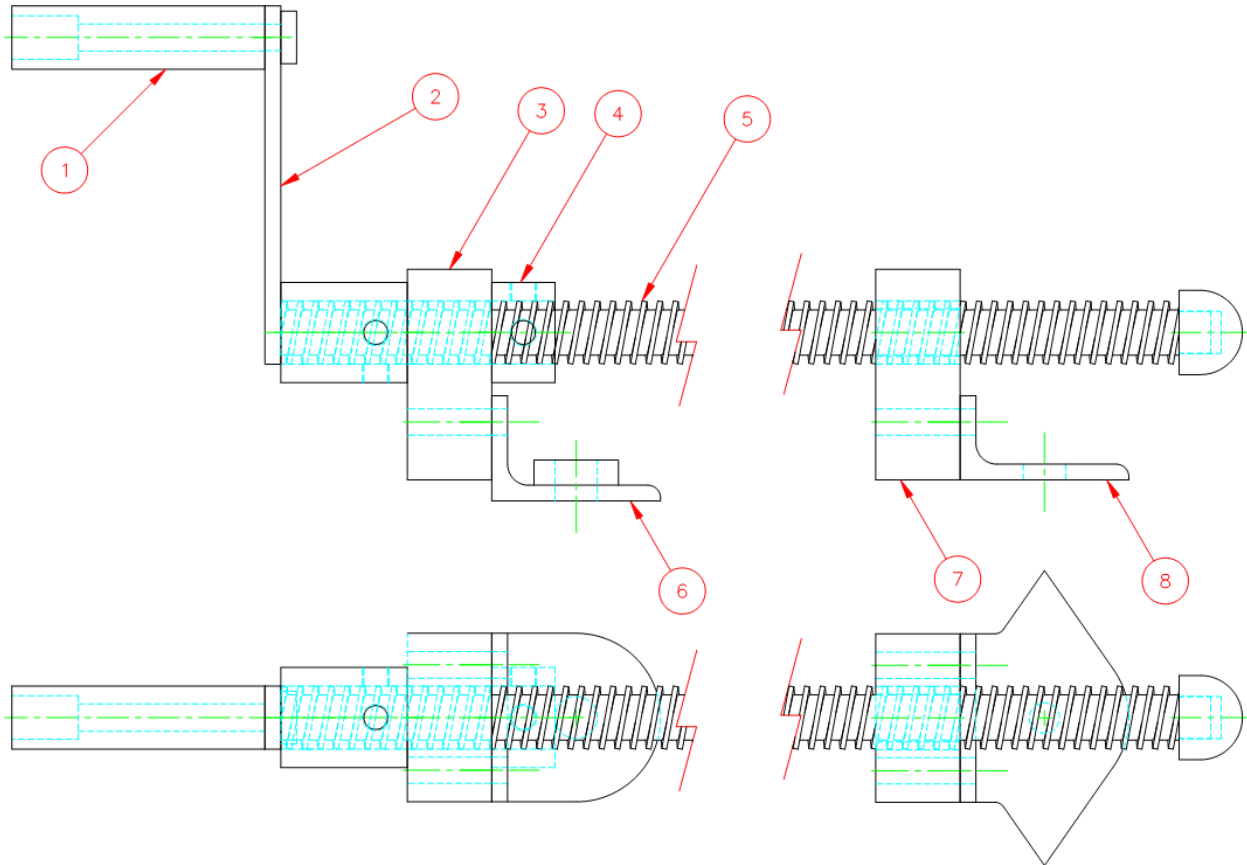

Ref. No.	Part Number	No. Req.	Description
1	30-38936-01-5	1	Handle, Discharge
2	20-25317-01-5	1	Handle, Weldment Discharge
3	30-38938-01-9	1	Pivot Block, Plastic
4	30-38941-01-5	1	Collar, Locking
5	20-25366-01-5	1	Shaft, Manual NF Gate
6	20-25358-01-5	1	Bracket, Angle Discharge
7	30-38937-01-9	4	Nut, Stationary Plastic
8	30-38934-01-5	1	Bracket, Gate Position Marker
9	30-38935-01-5	1	End Cap

6.2.4 MECHANICAL AUGER DISCHARGE (Standard before 10/2021)

The Auger Discharge is used in certain applications to assist with metering product out of the peel chamber such as high flow rate washing applications.

CAUTION

Keep all hands, feet, loose clothing, and foreign objects out of machine while it is operating. Always de-energize and lockout the machine when maintenance is required.

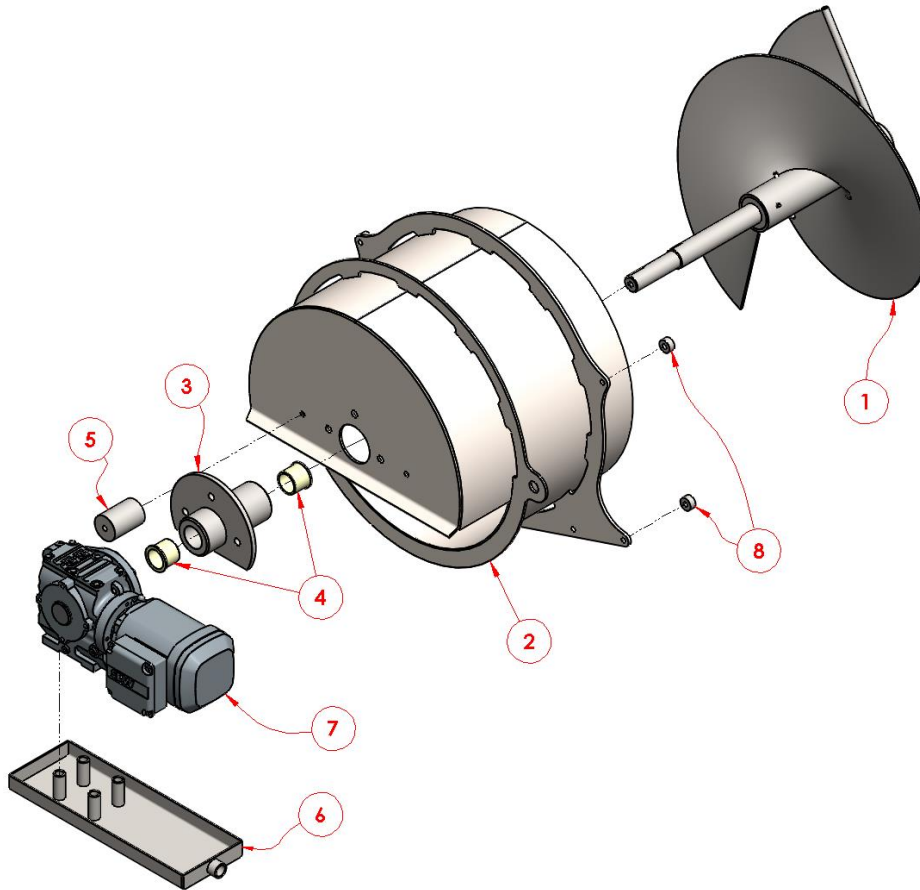

60-60634

Ref. No.	Part Number	No. Req.	Description
1	50-59227-01-5	1	Auger Assy. Mech
2	20-25585-01-5	1	Drum Weldment, Auger Discharge
3	20-24273-01-5	1	Housing, Discharge. Auger Shaft
4	40-43231-02-9	2	Bearing, SLV 1.50 Polymer w/flg 1.75 O.D.
5	30-31186-04-5	1	Spacer, 2.94" lg.
6	20-24851-01-5	1	Drip Pan, Mech. Auger Discharge
7	See Section 1.2	1	Gearmotor, 0.75 HP, Refer to tag for voltage & ratio
8	30-31186-05-5	4	Spacer, 0.50"

6.2.5 MECHANICAL AUGER DISCHARGE W/ PILOT (Standard after 10/2021)

The Auger Discharge is used in certain applications to assist with metering product out of the peel chamber such as high flow rate washing applications.

CAUTION

Keep all hands, feet, loose clothing, and foreign objects out of machine while it is operating. Always de-energize and lockout the machine when maintenance is required.

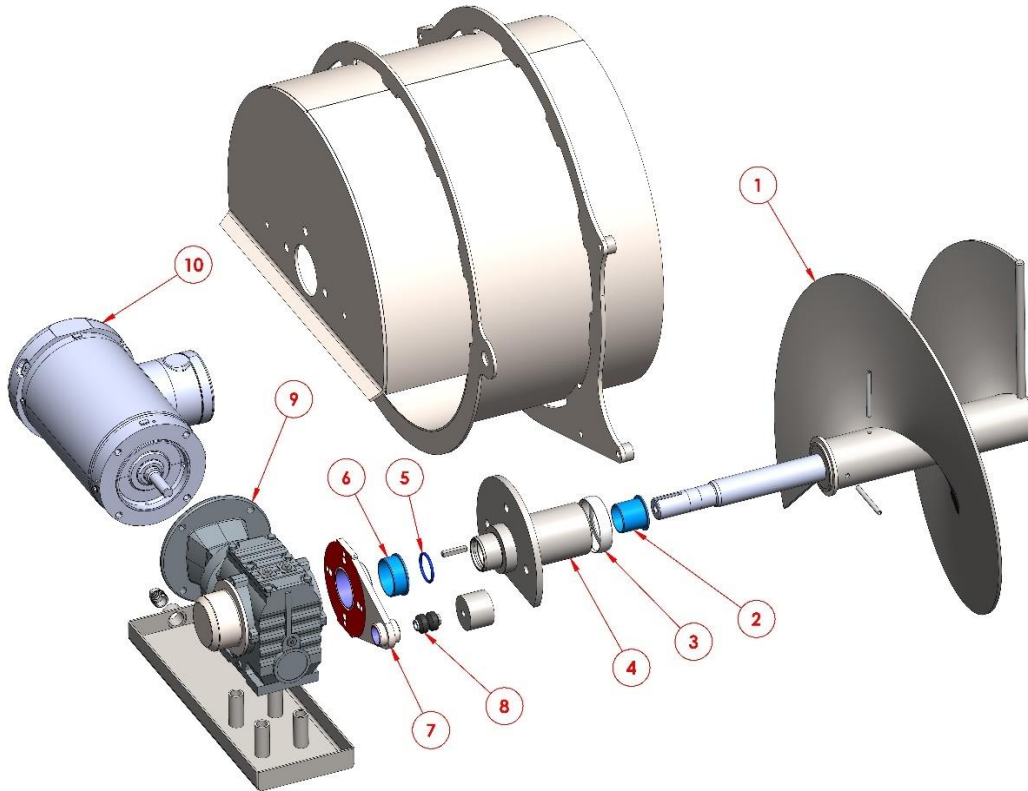

60-61020

Ref. No.	Part Number	No. Req.	Description
1	50-59227-02-5	1	Auger Assy. w/Pilot
2	40-43231-04-9	1	Brg, Slv 1.50 Polymer w/flange 1.66 OD
3	30-40631-01-9	1	Dust Cap, Auger Disch.
4	20-24273-02-5	1	Hub W/Pilot, Disch. Auger Shaft
5	40-44650-02-9	1	O-ring, 1.484 X 1.762 X .139 Blue
6	40-43231-05-9	1	Brg, Slv 2.00 Polymer W/Flange 2.25 OD
7	30-40644-01-5	1	Torque Arm, Machined W/ Pilot
8	40-44709-01-9	1	Bushing, Torque Arm
9	See Section 1.2		Reducer, WMGR Euro, Hollow Shft
10	See Section 1.2		Motor, 0.75HP

6.3 TUMBLING UNIT ASSEMBLY (02920)

The Tumbling Unit is used in certain applications to assist with product tumbling.

CAUTION

Keep all hands, feet, loose clothing, and foreign objects out of machine while it is operating. Always de-energize and lockout the machine when maintenance is required.

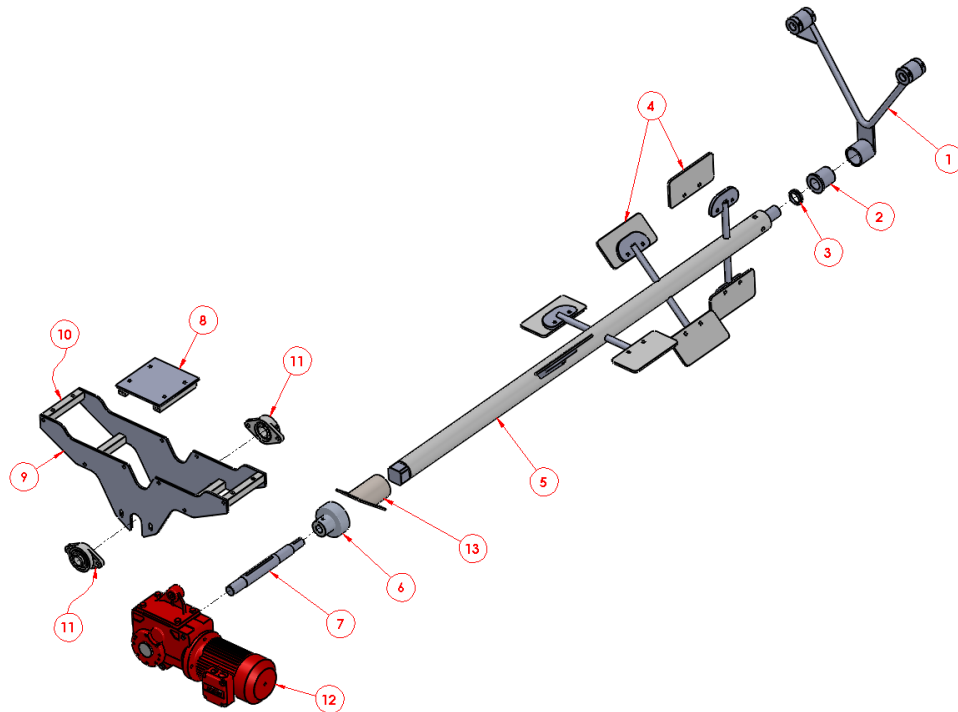

60627

Ref. No.	Part Number	No. Req.	Description
1	20-25575-01-5	1	Support, Tumbling Unit
2	30-39056-01-9	1	Bearing, Tumbling Unit
3	40-41419-01-9	1	Seal, V-Ring 1.42" ID
4	40-42813-01-9	8	Paddle, Tumbling Unit
5	20-22485-05-5	1	Shaft WLDMT, 4 Paddle @ 0°
	20-22485-06-5	1	Shaft WLDMT, 4 Paddle @ 15°
6	40-40236-01-9	1	Coupler, Urethane 1.00 w/ set screw
7	30-39070-01-5	1	Shaft, Drive Tumbling Unit
8	20-25576-01-5	1	Bracket, Torque Arm -Tumbler
9	30-39057-01-5	2	Support Plate, Tumbling Unit Drive
10	30-31489-01-5	4	Connector (4 Holes)
	30-31489-02-5	2	Connector (2 Holes)
11	40-40917-04-9	2	BRG, Ball FLG 2 BLT 1.25" COM
12	SEE SECTION 1.2	1	GMTR, 1.00HP,Refer to tag for voltage and ratio
13	50-59072-01-9	1	GUIDE, INLET CHUTE

6.4 TUMBLING UNIT ASSEMBLY (02922)

The Tumbling Unit is used in certain applications to assist with product tumbling.

CAUTION

Keep all hands, feet, loose clothing, and foreign objects out of machine while it is operating. Always de-energize and lockout the machine when maintenance is required.

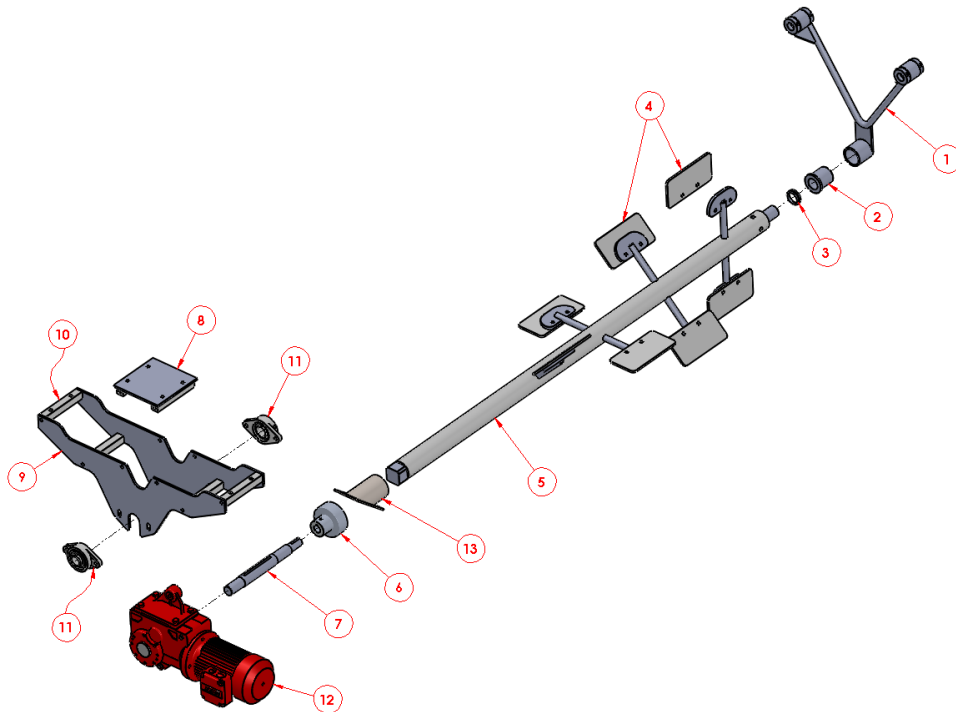

60627

Ref. No.	Part Number	No. Req.	Description
1	20-25575-01-5	1	Support, Tumbling Unit
2	30-39056-01-9	1	Bearing, Tumbling Unit
3	40-41419-01-9	1	Seal, V-Ring 1.42" ID
4	40-42813-01-9	14	Paddle, Tumbling Unit
5	20-25693-01-5	1	Shaft WLDMT, 7 Paddle @ 0°
	20-26111-02-5	1	Shaft WLDMT, 7 Paddle @ 15°
6	40-40236-01-9	1	Coupler, Urethane 1.00 w/ set screw
7	30-39070-01-5	1	Shaft, Drive Tumbling Unit
8	20-25576-01-5	1	Bracket, Torque Arm -Tumbler
9	30-39057-01-5	2	Support Plate, Tumbling Unit Drive
10	30-31489-01-5	4	Connector (4 Holes)
	30-31489-02-5	2	Connector (2 Holes)
11	40-40917-04-9	2	BRG, Ball FLG 2 BLT 1.25" COM
12	SEE SECTION 1.2	1	GMTR, 1.00HP, Refer to tag for voltage and ratio
13	50-59072-01-9	1	GUIDE, INLET CHUTE

6.5 REVERSING ROLLS

6.5.1 REVERSING ROLLS INSTALLATION

Refer to Section 4.8 for details on removal of the drive case and drive/roll shafts.

1. Remove square connectors from top of drive case and replace them with the round connectors supplied in the kit.
2. Remove the cap screws from the bearings on the shaft that is going to be reversed, and the shaft adjacent.
3. Move the shaft assemblies toward the center and loosen the set screws on the outer bearing and belt pulley.
4. Remove the bearing, pulley, and belt.
5. Slide the steel gear onto the shaft closest to the drive shaft, re-using the shaft key.
6. Slide the plastic gear onto the adjacent shaft also re-using the shaft key.
7. On the shaft closest to the driveshaft, re-install one belt pulley, and on both shafts, re-install the belt and bearings.
8. Re-install the cap screws in the bearings, align belt pulleys and tighten set screws.
9. Align the gears so they are flush, and the teeth are properly meshed. Lock both gears in position by tightening the set screws.

6.5.2 REVERSING ROLL PARTS OVERVIEW

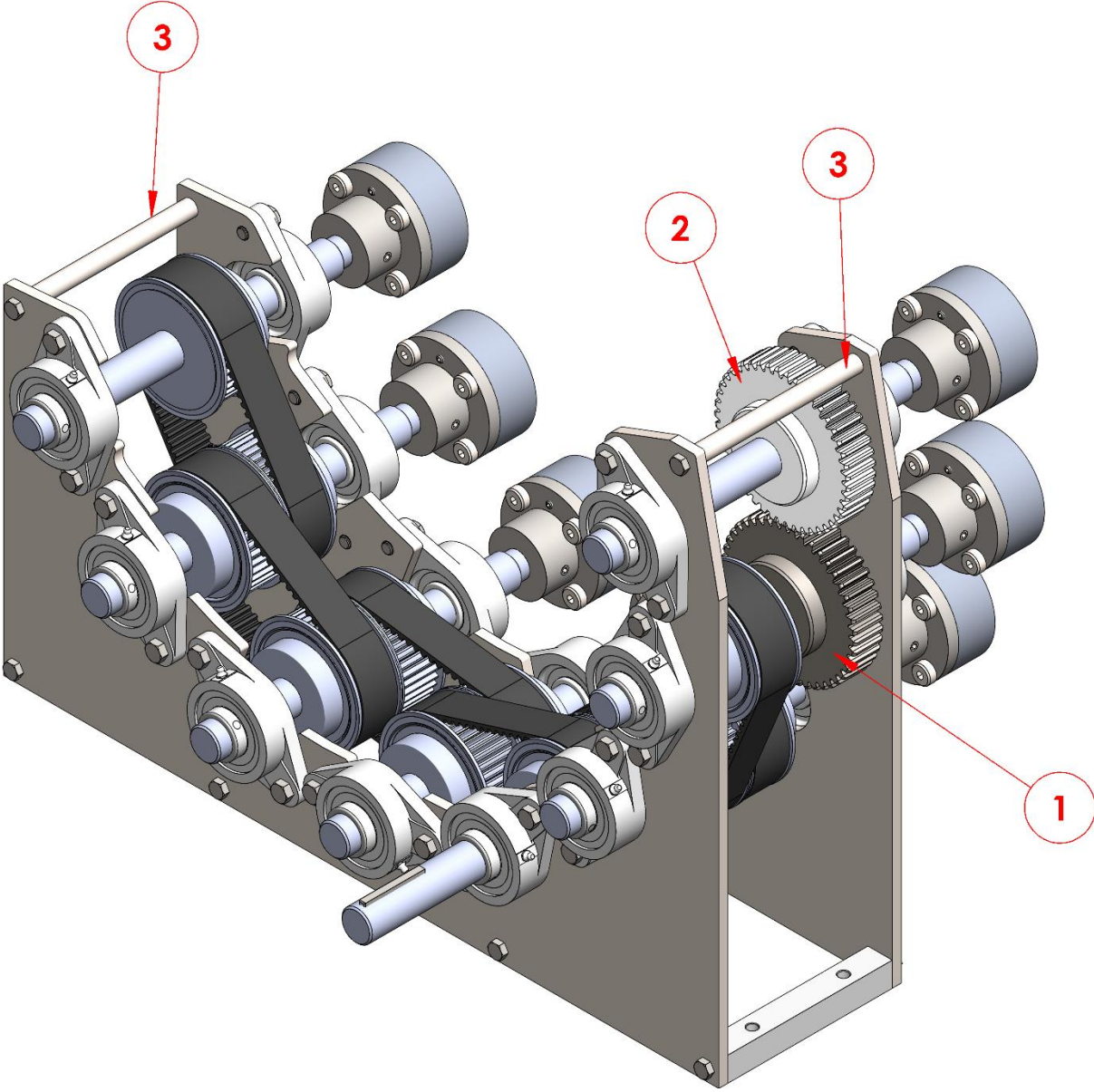

Ref No.	Part Number	No. Req.	Description
1	30-39115-01-9	1	Spur Gear – Steel, 135MM, 45T
2	30-39116-01-9	1	Spur Gear – Plastic, 135MM, 45T
3	30-39172-01-5	1	Connector, Round, 6.75 x .625

6.6 PAN SPRAY ASSEMBLY

The Pan Spray system is located beneath the peeling rolls as a series of spray bars with nozzles aimed towards the bottom side of the rolls. The spray pattern removes peel debris knocking from the roll down into the drain pan below. The water connection is located below the discharge gate area of the machine. Typical operation uses a solenoid valve operated on a timer. Vanmark recommends a cycle frequency of 1-minute ON / 30 minutes OFF, or as desired to clean brushes.

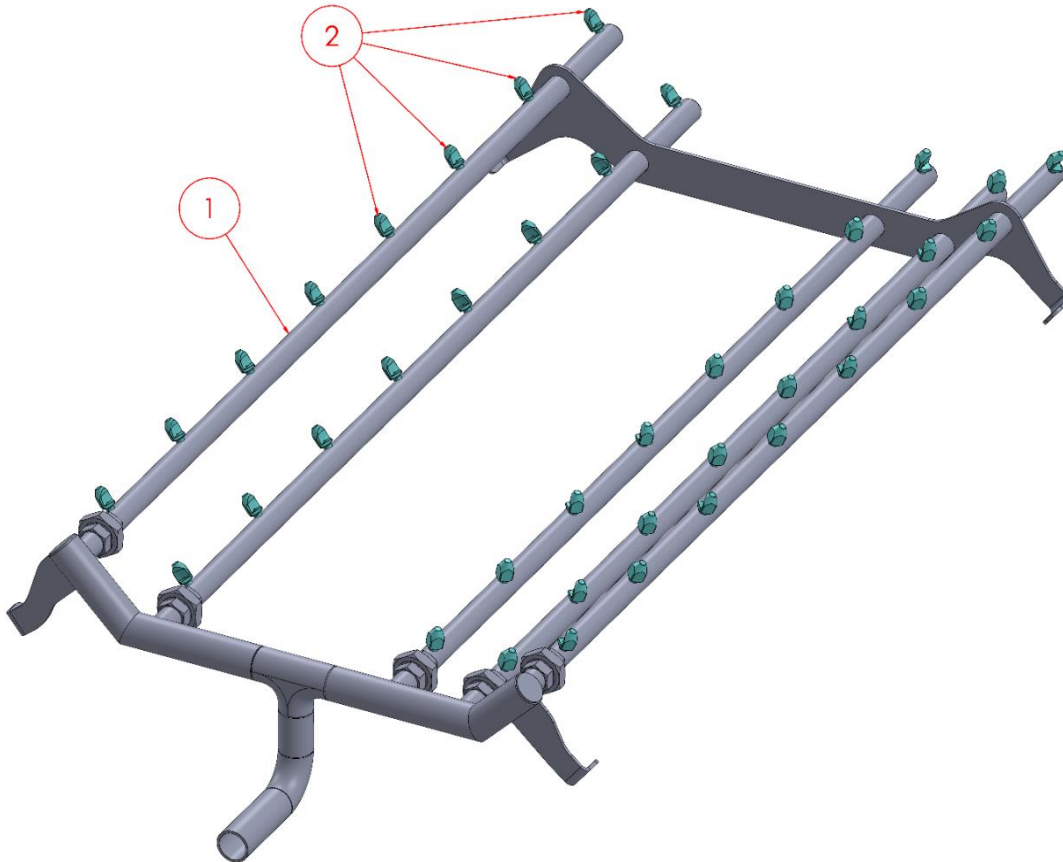

Ref No.	Part Number	No. Req. 02920	No. Req. 02922	Description
1	See Section 1.2	1		Pan Spray Bar Assembly
2	40-42503-03-9	40	55	Nozzle, FlatJet Spraying Systems (Brass)
2	40-42503-03-5			Nozzle, FlatJet Spraying Systems (Stainless Steel)

6.7 AUTO CIP SYSTEM

AUTOMATED CIP SYSTEM

The CIP (Clean-in-Place) System is an optional cleaning aid used with the Vanmark family of Peelers / Washers / Scrubbers. This system allows customers to gain an additional level of cleanliness in between and during regularly scheduled sanitation efforts. The optional Upper CIP focuses pressurized nozzles towards the sheet metal areas around the peel chamber pushing product residue down the sides of the peel bed and into the drain pan below. The Lower CIP spray bar is mounted beneath the peeling rolls and travels along the length of the peeler during washing cycles.

An optional controls package allows the user to program certain washing cycles or recipes for the system to run during production and/or sanitation processes. Depending on the options selected when the machine was purchased, your machine may be equipped with an Upper CIP system, a Lower CIP system, or both. Retro-fit kits are available to adapt this system to legacy peeler models or current models not originally supplied with the system.

It should be noted that depending on the family of Vanmark Peelers / Washers / Scrubbers purchased, the Upper and Lower CIP systems will vary. Example: the 02820 and 02822 family of Peelers have two peel chambers and will require the proper kit to outfit both peel chambers with the appropriate kits; please refer to the Data Sheet in section 1.2. For maximum cleanliness, it is recommended to utilize both the Upper and Lower CIP options at the customer's discretion.

A detailed overview including operation, retrofitting instructions (if applicable), maintenance, and troubleshooting is in the Automated CIP Operation Manual.

6.7.1 UPPER CIP

The Upper CIP (Clean-in-Place) System is an optional cleaning aid used with the Vanmark family of Peelers / Washers / Scrubbers. This system allows customers to gain an additional level of cleanliness in between and during regularly scheduled sanitation efforts.

The Upper CIP focuses pressurized nozzles towards the sheet metal areas around the peel chamber pushing product residue down the sides of the peel bed and into the drain pan below. This may be installed on its own in a peeler or coupled with the Automated CIP System described in Section 6.8.

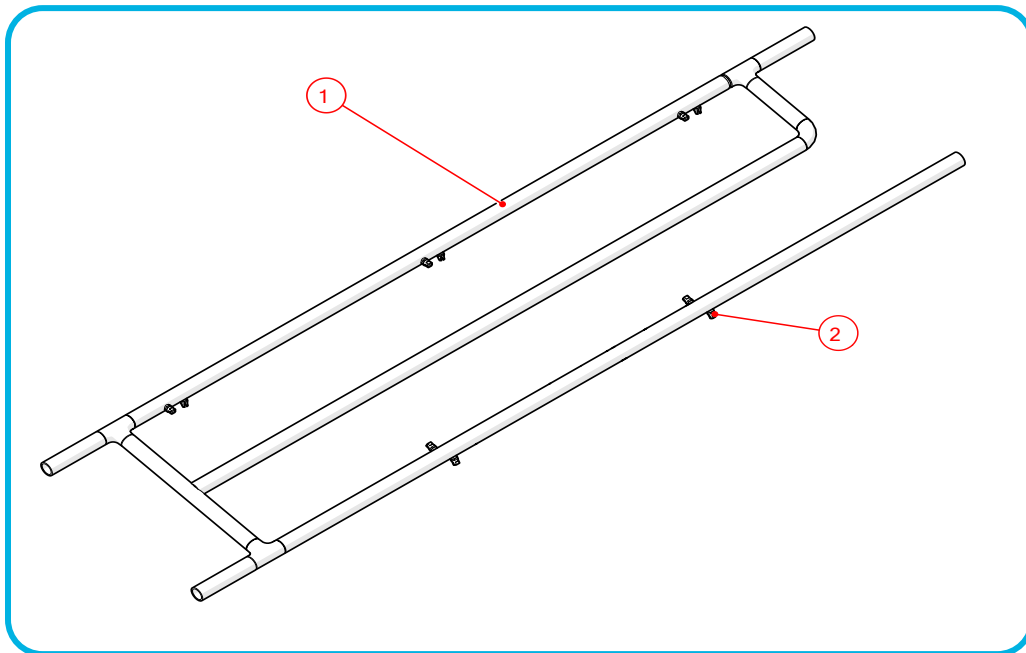
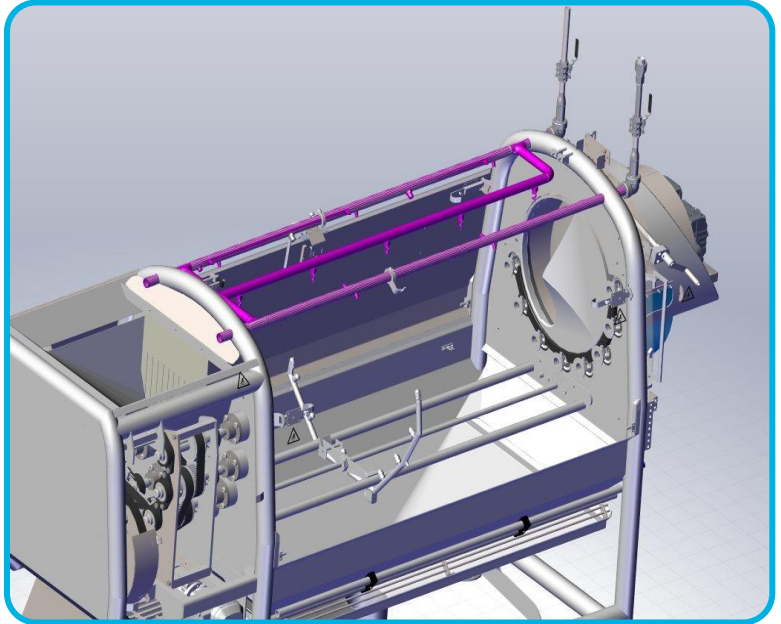

REF. NO.	PART NUMBER	QTY.	DESCRIPTION
1	See Section 1.2	1	SPRAY BAR, 0292X UPPER CIP
2	40-42477-13-5	21	NOZZLE, VEE JET SPRAYING SYSTEMS

6.7.2 LOWER CIP

The Lower CIP is designed to travel under the peeling rolls along the length of the bed spraying pressurized water onto the moving rolls and sides of the peel chamber, flushing product residue and waste down into the drain pans. This provides a more effective and efficient clean on the rolls than traditional fixed spray bar systems.

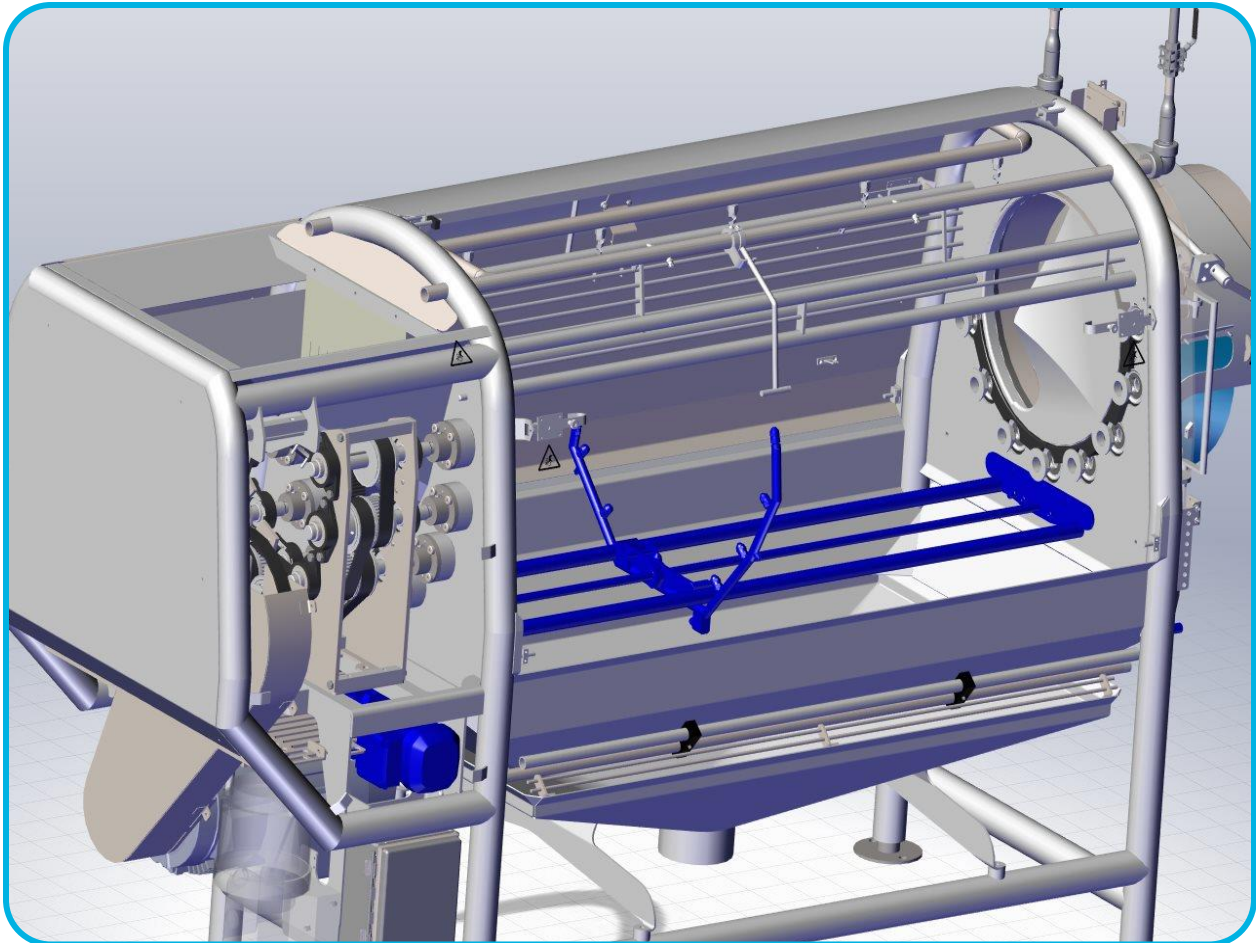

6.7.3 CONTROL SYSTEM

Vanmark has developed an optional controls solution for either the Lower CIP or the combination of the Lower CIP and Upper CIP System in a Peeler. The control system consists of an HMI [Human-Machine Interface] touchscreen to operate the system. Programmable cycles or “recipes” may be setup for washing operations during production and/or sanitation processes. For detailed operation details, please refer to the Automated CIP Operation Manual.

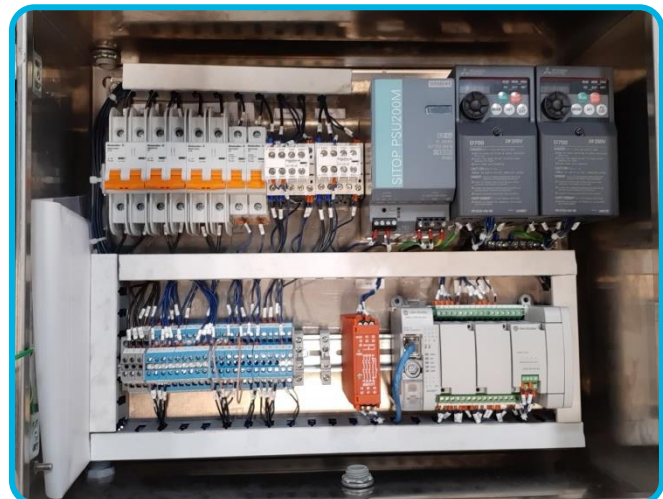

6.7.4 UTILITY CONNECTIONS

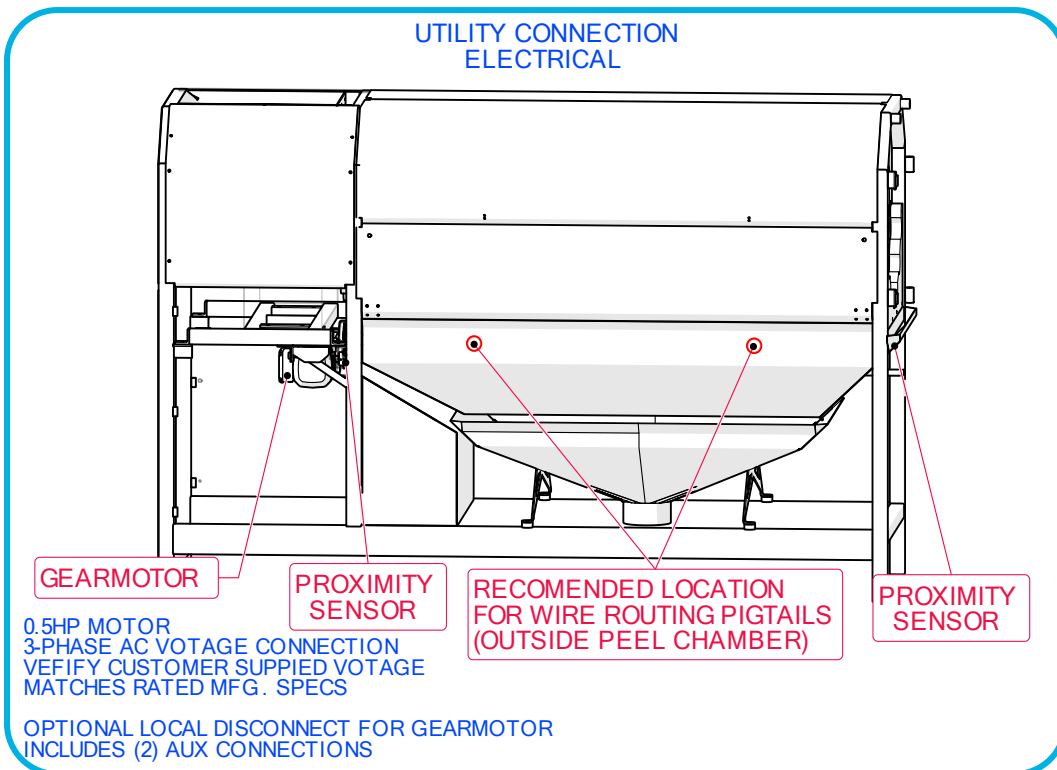
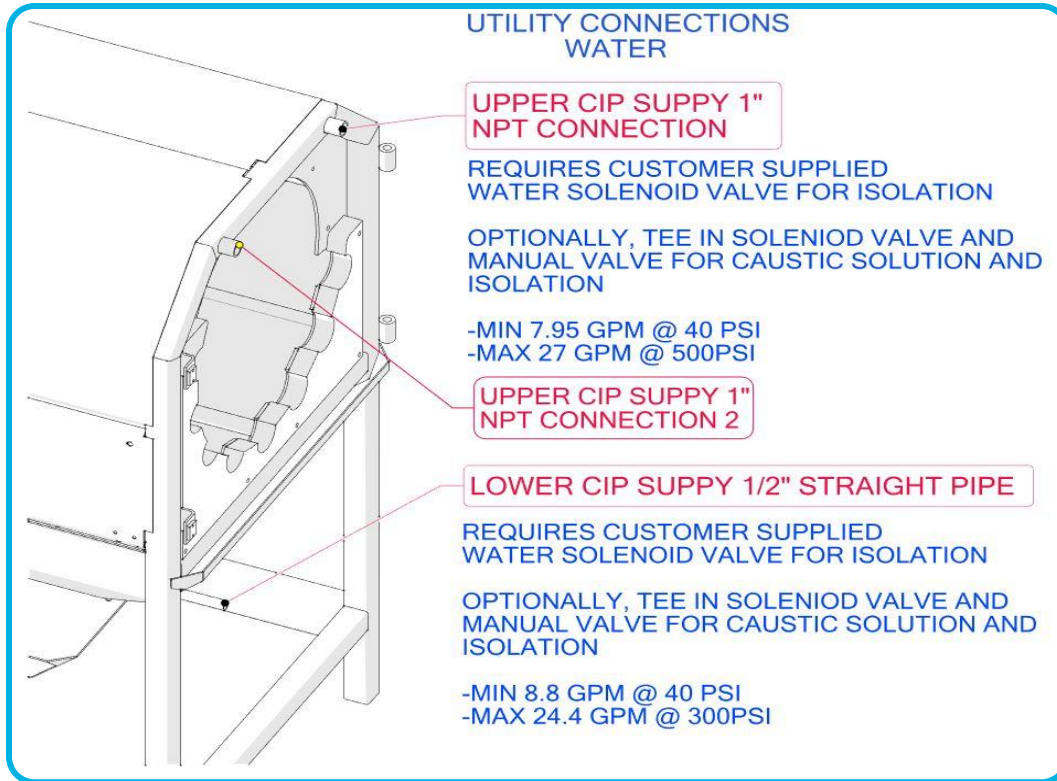

6.7.5 TROUBLESHOOTING

SYMPTOM / PROBLEM	POSSIBLE CAUSE	SOLUTION
Spray Bar is Bound/Jammed	Build up on Threaded Drive Bar	Remove Debris/Clean the Threaded bar
	Worn or Damaged Guide Nut	Replaced Guide Nut
	Too much product in peeling chamber	Adjust discharge gate (See Adjustments Section), Maintain even infeed
	Worn/damaged spray bar guides	Check spray bar guides for wear, replace if necessary
Spray Bar Crashes	Faulty Sensor/s	Check Sensor for proper operation/function, replace if necessary
	Controls Error	Review Controls Troubleshooting and Operation in the Automated CIP Manual, contact Vanmark Equipment
Uneven or Lack of Cleaning	Clogged Nozzle/s	Remove and clean nozzles to free any debris
	Worn/damaged spray bar guides	Check spray bar guides for wear, replace if necessary
	Lack of Water Supply	Check water supply for proper flow and pressure, and all connections

6.7.6 LOWER CIP PARTS LIST

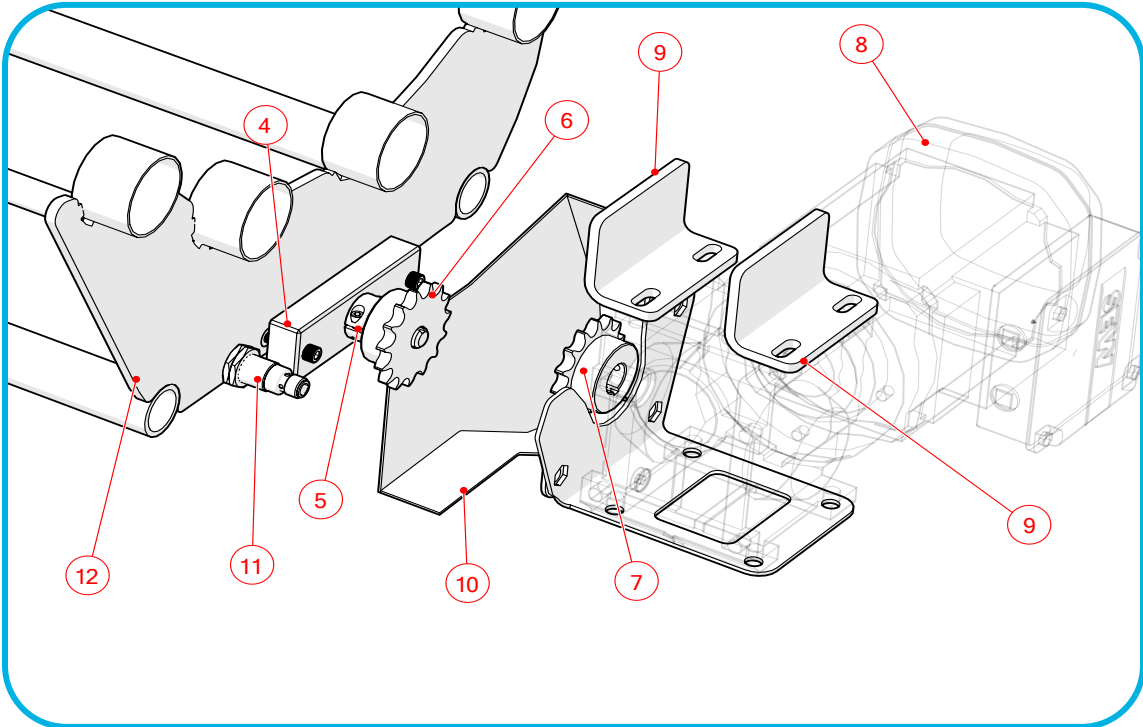
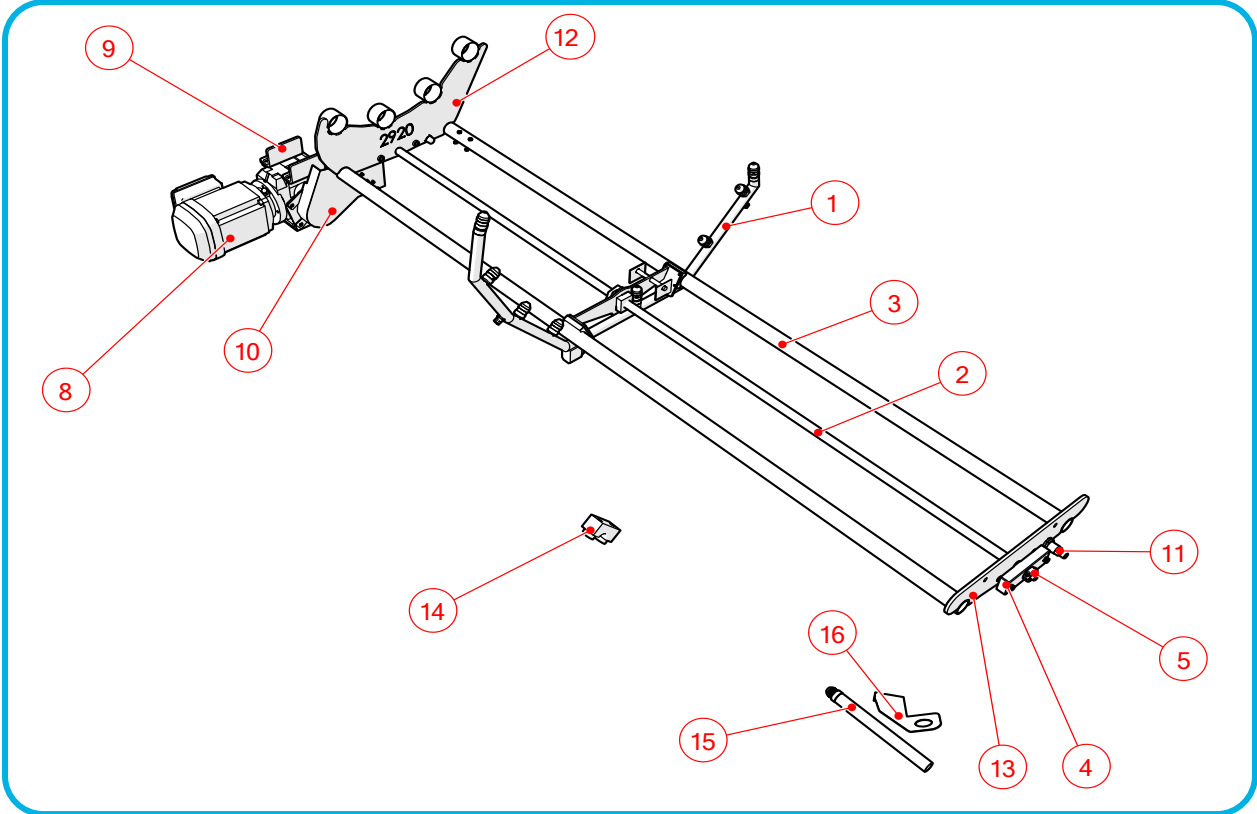

To feed our growing world - Together

300 Industrial Parkway, Creston, IA 50801, USA
 Phone: +1 740-201-0004
 vanmark.com

02920 / 02922 PEELER MANUAL
 REV. A 2020

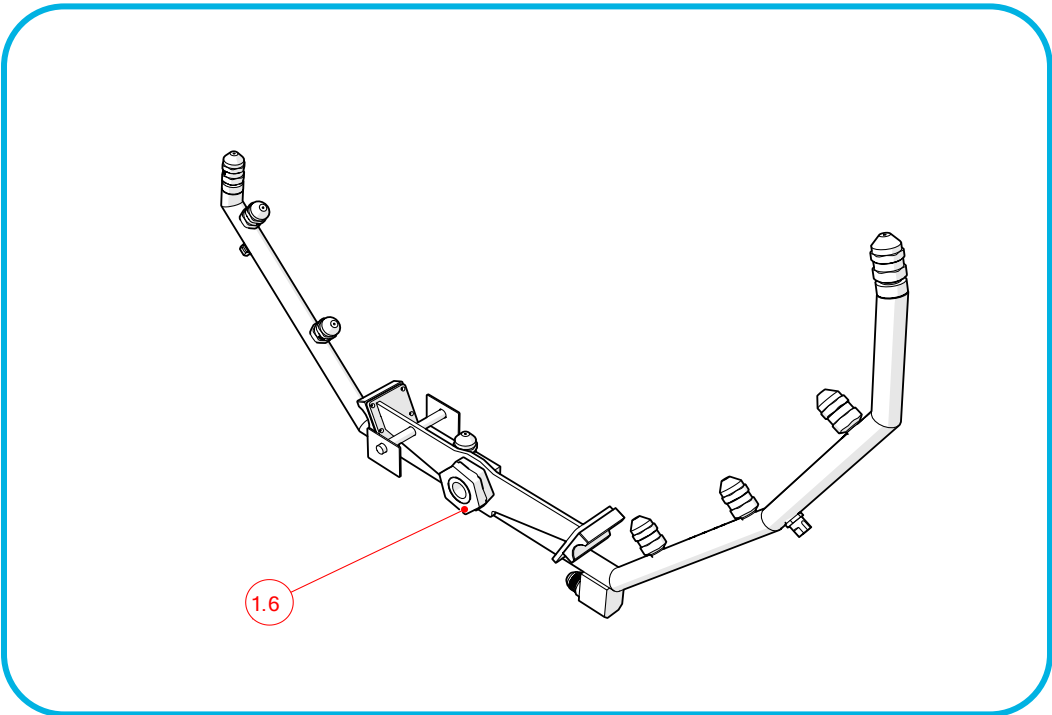
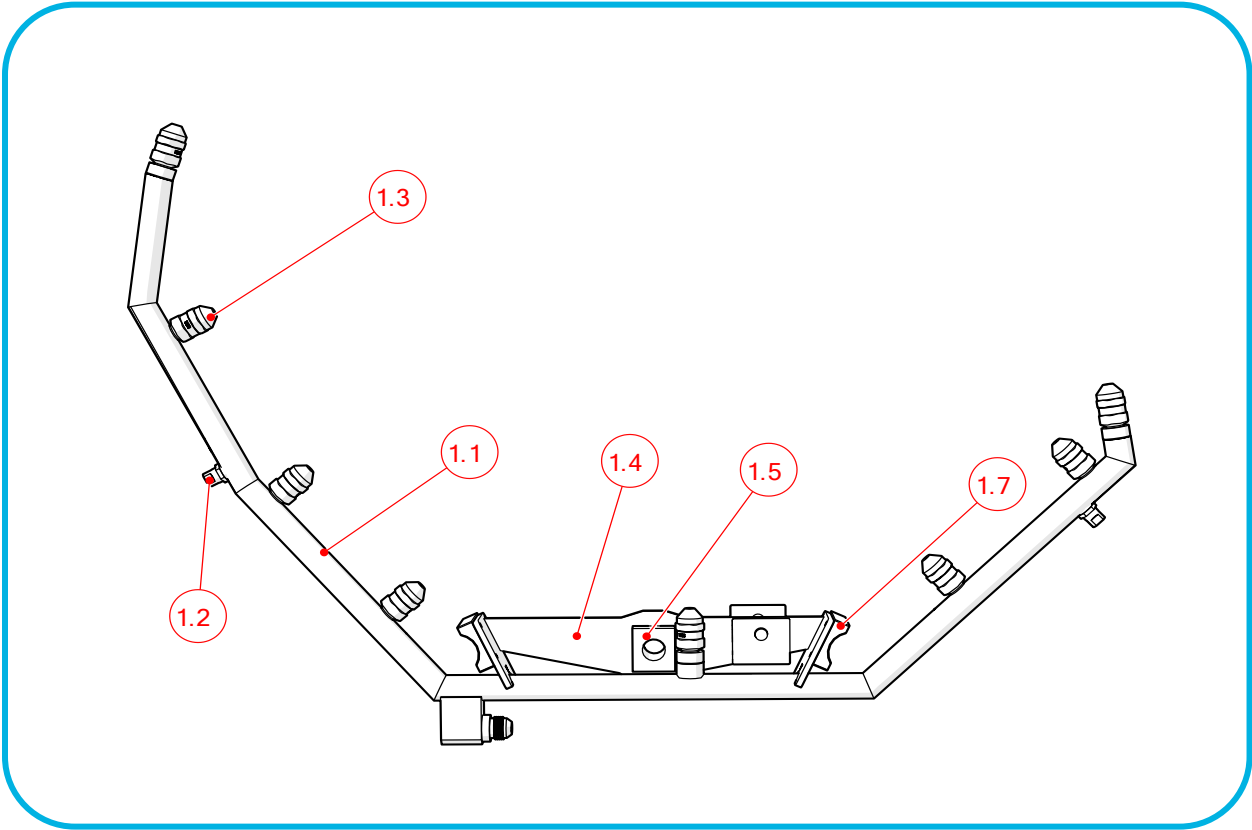

To feed our growing world - Together

300 Industrial Parkway, Creston, IA 50801, USA
Phone: +1 740-201-0004
vanmark.com

02920 / 02922 PEELER MANUAL
REV. A 2020

REF. NO.	PART NUMBER	QTY.	DESCRIPTION
1	50-59582-01-5	1	SPRAY BAR ASSY, 2920 CIP
1.1	20-28724-01-5	1	SPRAY BAR
1.2	40-42477-14-5	2	NOZZLE, VEEJET - 1/4VV-SS 11010
1.3	40-41991-03-5	8	NOZZLE, FULL JET
1.4	30-40583-03-5	1	SPRAY BAR MOUNT, CIP
1.5	30-40550-02-9	1	ACME SCREW NUT, .75-5
1.6	30-40549-01-5	2	JAM NUT, 1.25-12 HEX STR THD, 0.375 THK
1.7	30-40430-02-9	2	WEAR GUIDES, CIP
1.8	48-48462-01-5	8	SCR, 6-32X .5 SLTD PAN MACH
2*	See Section 1.2 in Automated CIP Manual	1	ACME THREADED ROD, 2920 CIP
3*	See Section 1.2 in Automated CIP Manual	2	PIPE SUPPORT, 2920 CIP
4	30-40428-01-9	2	BEARING BLOCK, SCREW SUPPORT CIP
5	40-44692-01-5	2	SHAFT COLLAR, CLAMPING TWO-PIECE .5" ID
6	40-44770-01-1	1	SPROCKET, 40 B .50" BORE, 15 TEETH
7	40-44769-01-1	1	SPROCKET, 40 B .75" BORE, 15 TEETH
8	40-43265-68-9	1	GMTR, 0.50HP 90 266/460 3 60C US
9	30-40792-01-5	1	MOTOR BRACE, 2920 CIP
10	21-20261-03-5	1	CHAIN COVER, CIP 2920 Retro
11	40-43516-09-9	2	SWITCH, PROX INDUCTIVE 20-140 VAC/DC NO
12*	50-59583-01-5	1	INFEEED TEMPLATE ASSY, 2920 CIP (Retro-Fitting Only)
13*	50-59584-01-5	1	DISCHARGE TEMPLATE ASSY, 2920 CIP (Retro-Fitting Only)
14	30-40764-01-9	1	HOSE CLAMP, CIP UHMW
15	21-20159-01-5	1	CONNECTION, LOWER CIP WELDED BUNG
16	21-20158-02-5	1	TEMPLATE, LOWER CIP 2700 PIPE FITTING

17	40-40090-01-5	2	CHAIN, RLLR # 40 .50 PITCH SS
18	40-40010-01-5	2	LINK, CONN # 40 SS
19	40-40524-01-5	1	LINK, OFFSET # 40 SS
20	40-44718-03-5	1	CIP HOSE ASSEMBLY, .5" FORTRESS 300 HOSE

Automated CIP Spare Parts

REF. NO.	PART NUMBER	STD. QTY.*	HEAVY DUTY QTY.*	DESCRIPTION
1.5	30-40550-02-9	1	2	ACME SCREW NUT, .75-5
1.7	30-40430-02-9	2	4	WEAR GUIDES, CIP
4	30-40428-01-9	2	2	BEARING BLOCK, SCREW SUPPORT CIP
15	40-40090-01-5	2	2	CHAIN, RLLR # 40 .50 PITCH SS
16	40-40010-01-5	2	2	LINK, CONN # 40 SS
17	40-40524-01-5	1	1	LINK, OFFSET # 40 SS
20	40-44718-03-5	1	2	CIP HOSE ASSEMBLY, .5" FORTRESS 300 HOSE

NOTICE

*** Part listed is for standard machine. See Section 1.2 Data Sheet for available options/alternate part numbers. Heavy Duty quantities are recommended for high use or harsh applications of the system.**

7.0 SPARE PARTS (SUGGESTED)

7.1 02920 SPARE PARTS

Part Number	Est. Qty/Year		Description
	Intermit	Cont.	
20-20779-01-5	2	4	SHAFT ASSEMBLY, Peeling Roll
30-38947-02-5	1	2	SHAFT, Peeling Roller (Steel Drive Case)
30-38947-03-5	1	1	SHAFT, STEEL DRIVE CASE, DRIVE
20-20249-01-1	1	2	NUT ASSEMBLY, Peeling Roller
40-43731-01-9	1	1	SPROCKET, Drive Case Roll
40-42937-13-9	1	2	BELT, Drive Case Timing
40-43793-05-9	1	1	BELT, Drive Case Drive Belt
See Section 1.2	1	1	SPROCKET, Motor Drive
See Section 1.2	1	1	SPROCKET, Motor Driven
50-59342-01-5	1	2	BEARING, BALL CYL 1.19 STAINLESS
40-43734-01-9	2	2	BEARING BLOCK CLAMP
40-40917-04-9	2	2	BEARING, 2 Bolt Flange - 1.25 Bore – Drive
60-60660-01-5	2	2	COUPLER, QUICK CHANGE ASSY, 1.00 B
50-59359-01-9	2	2	REPLACEMENT COUPLER W/BOLTS

For Machines Equipped w/Natural Flow Gate Discharge			
30-38938-01-9	1	1	PIVOT BLOCK, Plastic Natural Flow
30-38937-01-9	1	1	BLOCK, Threaded
30-38939-01-9	1	2	GUIDE, Natural Flow Gate Rotation
30-38993-01-9	1	2	CHUTE EXTENSION, Natural Flow Gate

For Machines Equipped w/Auger Discharge (w/pilot)			
50-59227-02-5	1	1	AUGER ASSY. W/PILOT
40-43231-04-9	1	2	BRG, SLV 1.50 POLYMER W/FLANGE 1.66 OD
30-40631-01-9	1	2	DUST CAP, AUGER DISCH.
40-44650-02-9	1	2	O-RING, 1.484 X 1.762 X .139 BLUE
40-43231-05-9	1	2	BRG, SLV 2.00 POLYMER W/FLANGE 2.25 OD

NOTE: Quantities to have on hand for standard intermittent use are based on a production schedule of eight (8) hours per day, five (5) days per week with at least one year of such usage anticipated.

Quantities to have on hand for continuous use are based on a production schedule of twenty-four (24) hours per day, five (5) days per week with at least one year of such usage anticipated.

7.2 02922 SPARE PARTS

Part Number	Est. Qty/Year		Description
	Intermit	Cont.	
20-20779-04-5	2	4	SHAFT ASSEMBLY, Peeling Roll
30-38947-02-5	1	2	SHAFT, Peeling Roller (Steel Drive Case)
30-38947-03-5	1	1	SHAFT, STEEL DRIVE CASE, DRIVE
20-20249-01-1	1	2	NUT ASSEMBLY, Peeling Roller
40-43731-01-9	1	1	SPROCKET, Drive Case Roll
40-42937-13-9	1	2	BELT, Drive Case Timing
40-43793-05-9	1	1	BELT, Drive Case Drive Belt
See Section 1.2	1	1	SPROCKET, Motor Drive
See Section 1.2	1	1	SPROCKET, Motor Driven
50-59342-01-5	1	2	BEARING, BALL CYL 1.19 STAINLESS
40-43734-01-9	2	2	BEARING BLOCK CLAMP
40-40917-04-9	2	2	BEARING, 2 Bolt Flange - 1.25 Bore – Drive
60-60660-01-5	2	2	COUPLER, QUICK CHANGE ASSY, 1.00 B
50-59359-01-9	2	2	REPLACEMENT COUPLER W/BOLTS

For Machines Equipped w/Natural Flow Gate Discharge			
30-38938-01-9	1	1	PIVOT BLOCK, Plastic Natural Flow
30-38937-01-9	1	1	BLOCK, Threaded
30-38939-01-9	1	2	GUIDE, Natural Flow Gate Rotation
30-38993-01-9	1	2	CHUTE EXTENSION, Natural Flow Gate

For Machines Equipped w/Auger Discharge (w/pilot)			
50-59227-02-5	1	1	AUGER ASSY. W/PILOT
40-43231-04-9	1	2	BRG, SLV 1.50 POLYMER W/FLANGE 1.66 OD
30-40631-01-9	1	2	DUST CAP, AUGER DISCH.
40-44650-02-9	1	2	O-RING, 1.484 X 1.762 X .139 BLUE
40-43231-05-9	1	2	BRG, SLV 2.00 POLYMER W/FLANGE 2.25 OD

NOTE: Quantities to have on hand for standard intermittent use are based on a production schedule of eight (8) hours per day, five (5) days per week with at least one year of such usage anticipated.

Quantities to have on hand for continuous use are based on a production schedule of twenty-four (24) hours per day, five (5) days per week with at least one year of such usage anticipated.

8.0 CHARTS & SCHEMATICS

8.1 PEELING ROLL CONFIGURATION

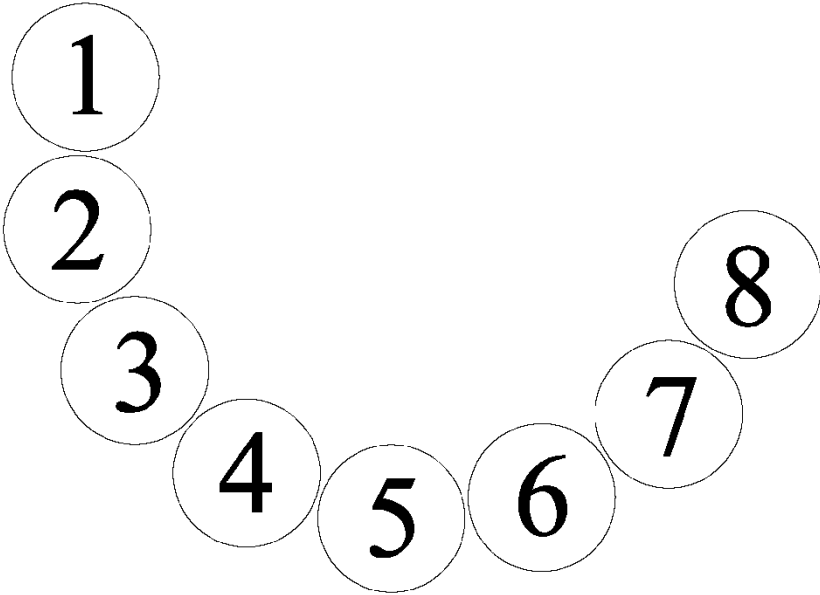

DISCHARGE END VIEW

Roll No.	Part Number	Roll Type
1		
2		
3		
4		
5		
6		
7		
8		

NOTE: No. 1 and 8 rolls are not used in 6 roll units

8.2 TERMINAL BLOCK ENCLOSURE

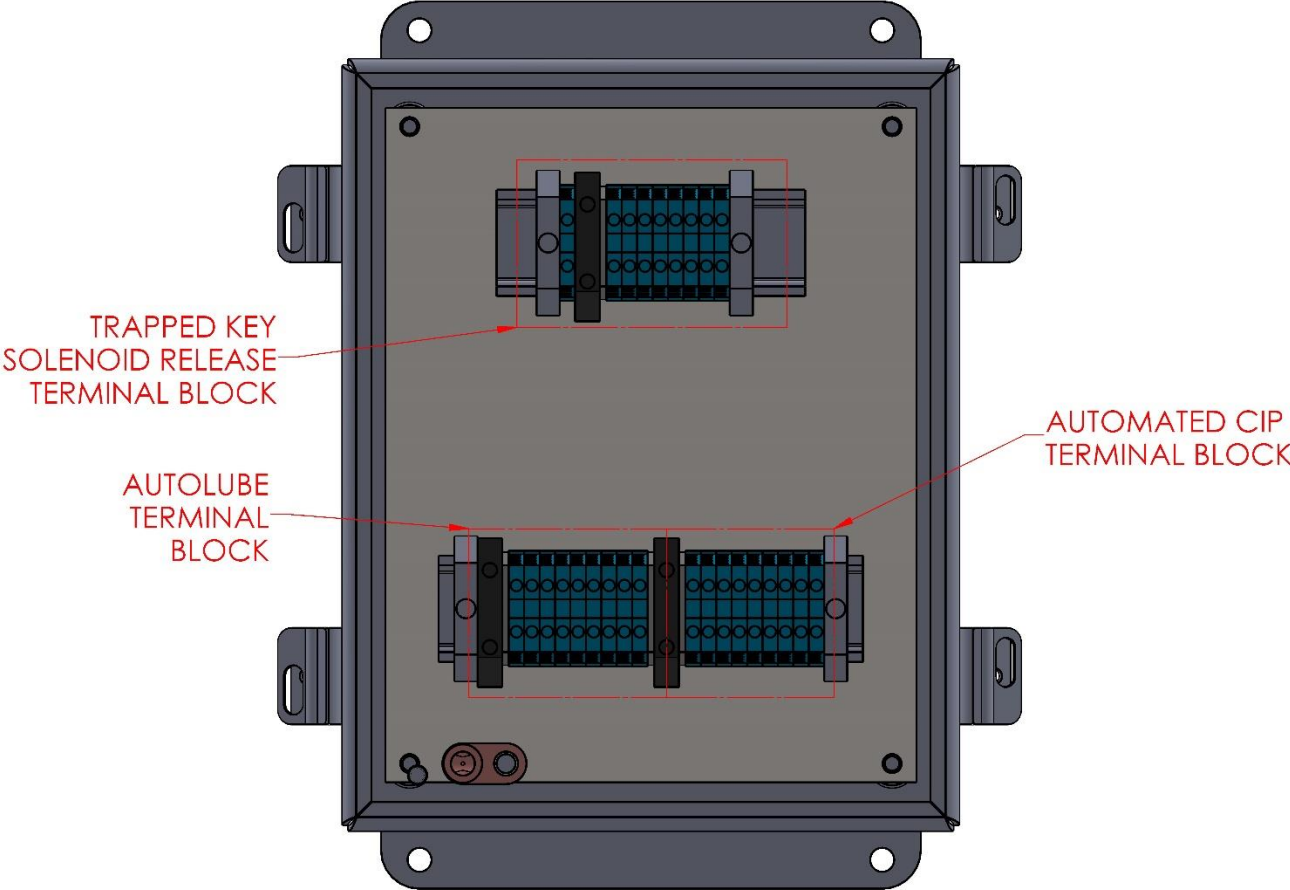

8.4 RECOMMENDED WATER SCHEMATIC

MODEL 2920

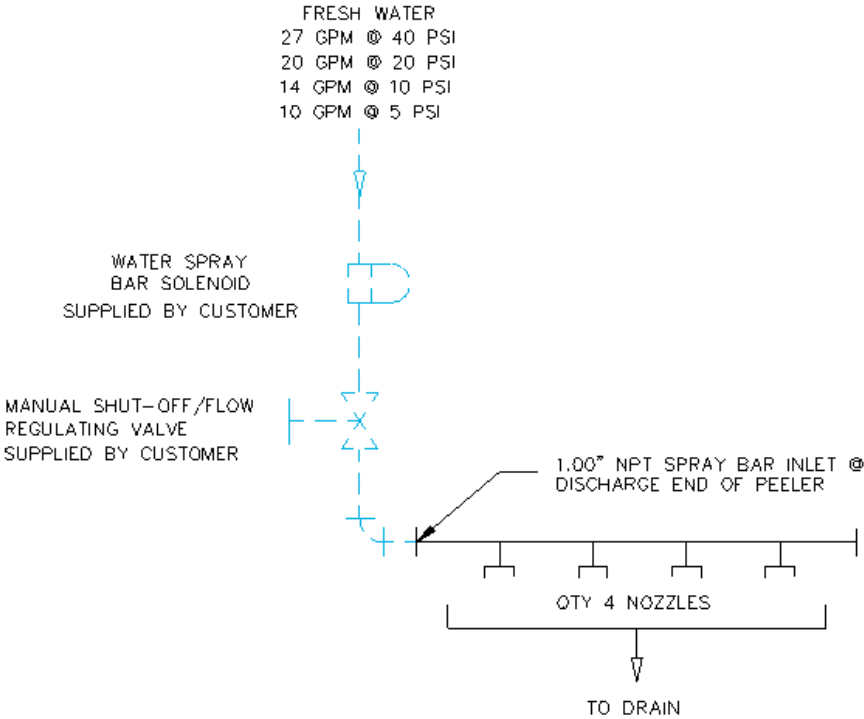

MODEL 2922

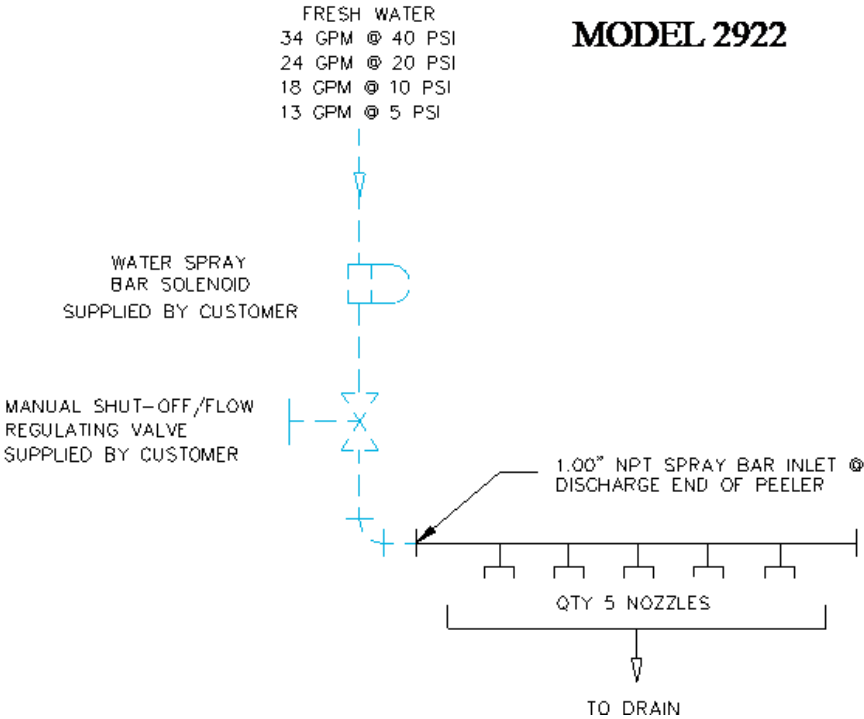

8.5 IDEM TRAPPED KEY SOLENOID RELEASE WIRING

8.5.1 24VDC WIRING SCHEMATIC

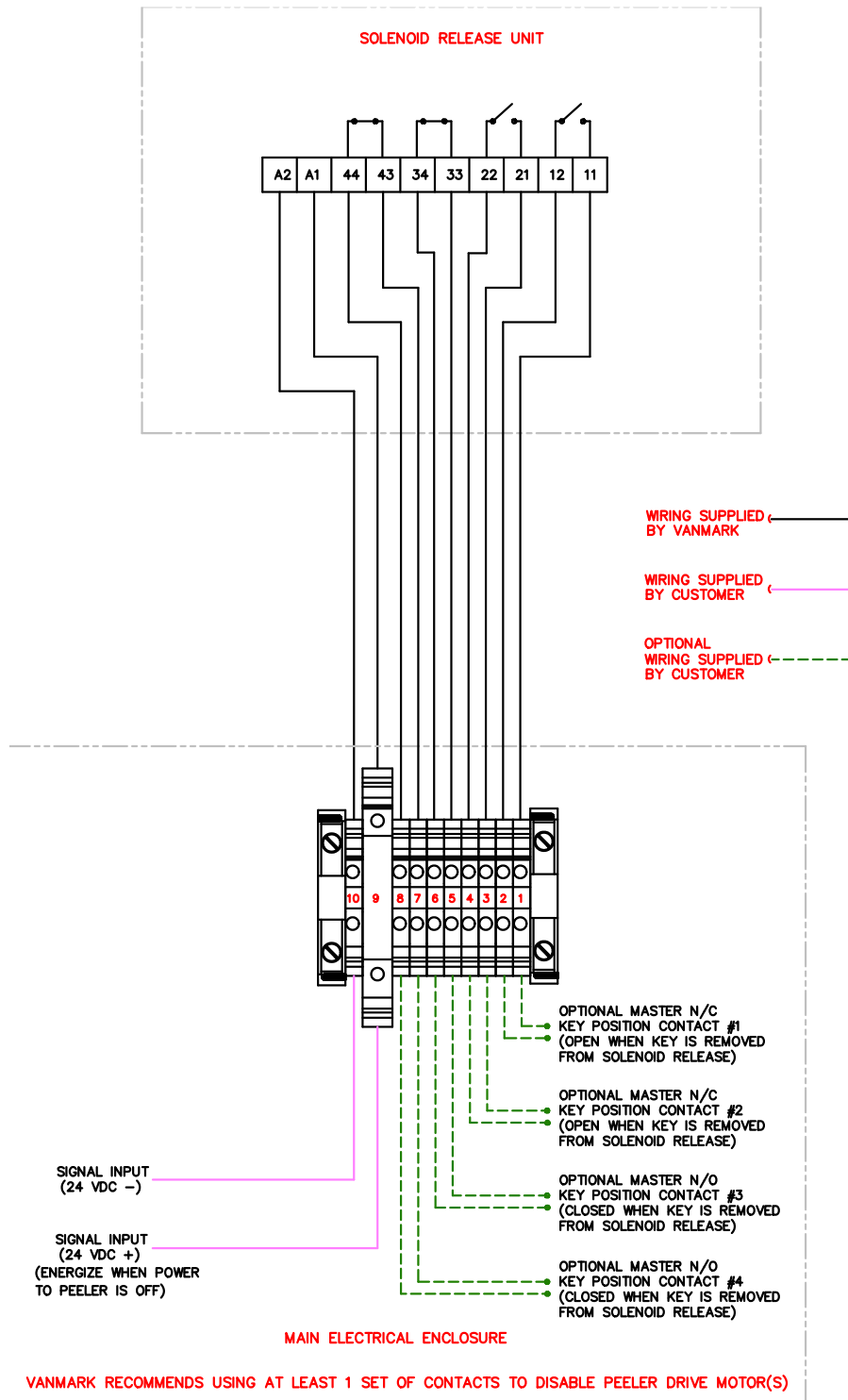

8.6 LINCOLN AUTOMATIC LUBE WIRING SCHEMATIC

8.6.1 24VDC WIRING SCHEMATIC

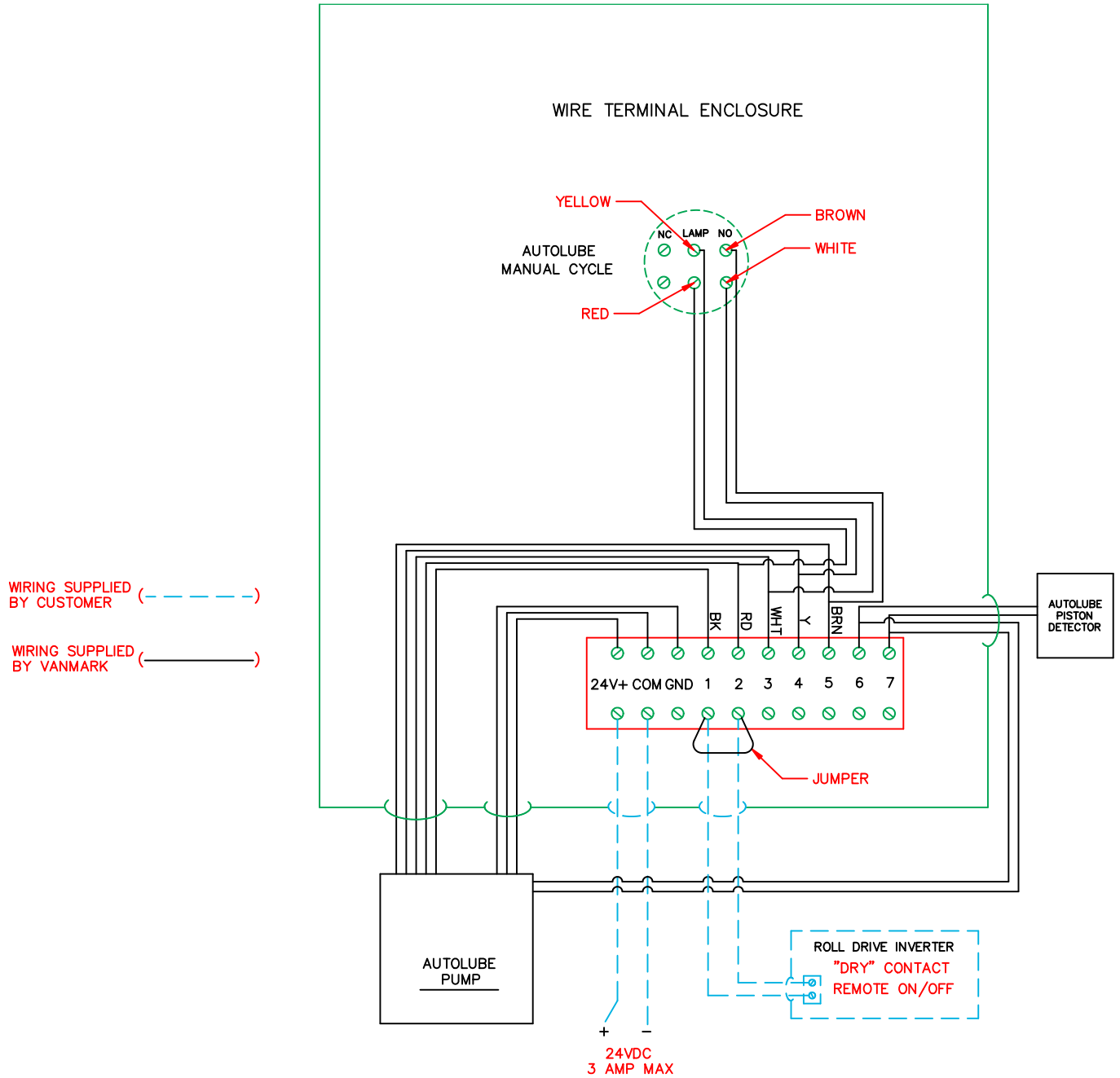

50-59346-02

8.6.2 120VAC WIRING SCHEMATIC

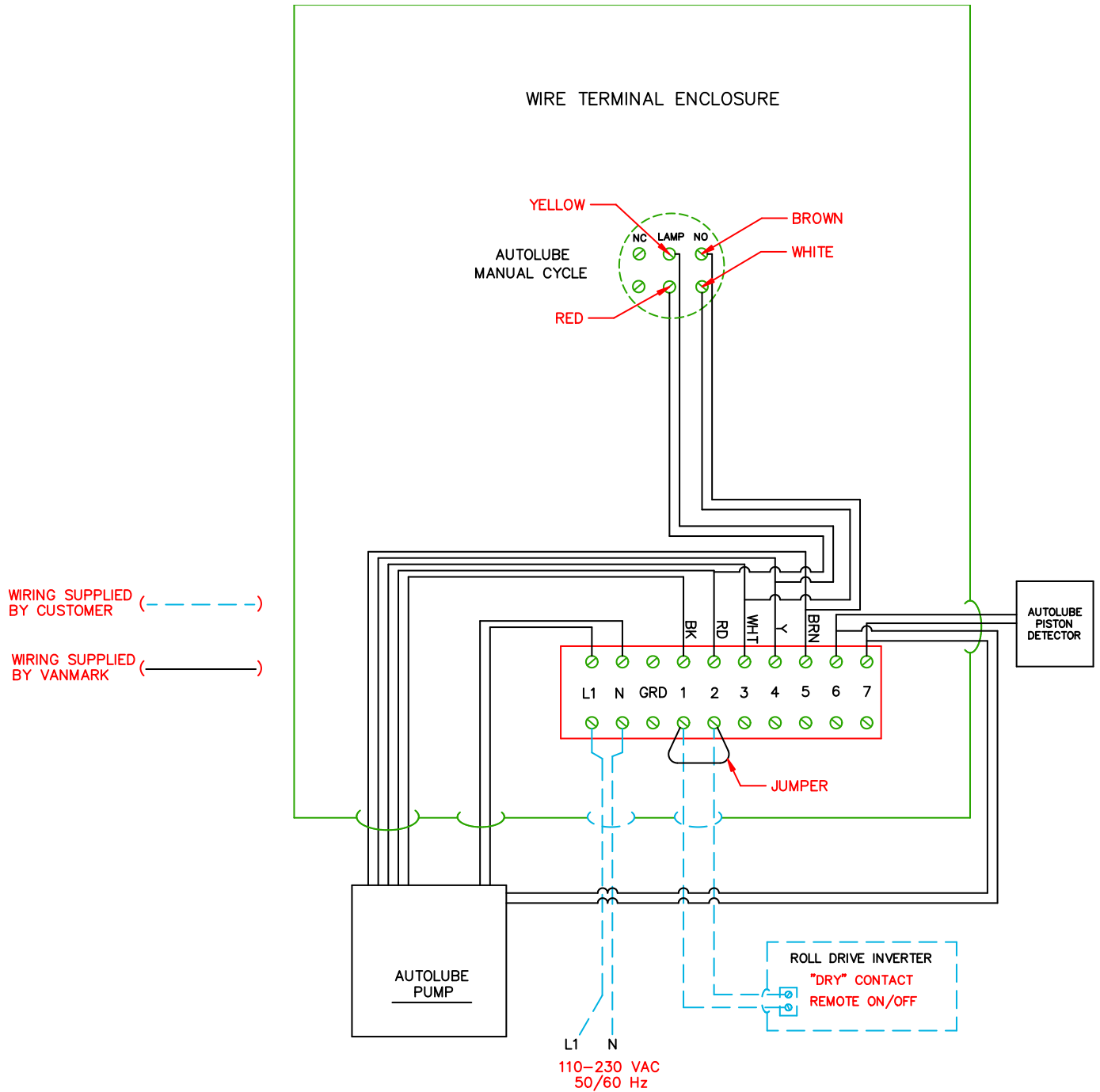

50-59346

8.7 DRIVE MOTOR Hz TO RPM CONVERSION

Inverter Hz	<u>02920</u> RPM	<u>02922</u> RPM
20	122	127
25	153	158
30	183	190
35	214	222
40	244	253
45	275	285
50	305	317
55	336	348
60	366	380
65	397	411
70	428	443
75	458	475
80	489	507
85	519	538
90	550	570

9.0 COMPONENT CUT SHEETS

Subcomponent cut sheets are provided in electronic form with the equipment. If any replacement cut sheets are needed, please contact Vanmark Equipment, and provide the equipment serial number from Section 1.2.

Cut Sheets Provided (If Applicable):

- Lincoln Central Lubrication Pump
- Trap Key
 - Key Access
 - Key Exchange
 - Solenoid Release Unit