

Hydrolift Destoner

Vertically Lift Product
& Separate Rocks and Debris

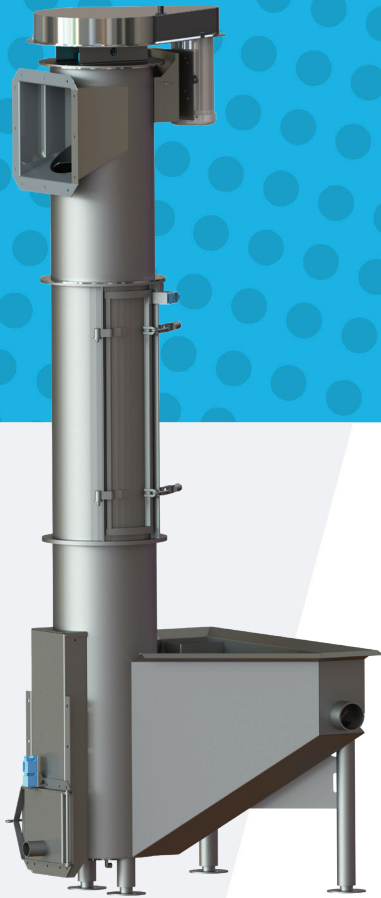

The Hydrolift Destoner vertical auger simultaneously rinses and removes debris and rocks from dirty product, while elevating it to the next step in your process. Its constant speed, auger design, and water circulation keep product moving up the screw while rocks settle at the bottom of the tank. Debris can be removed automatically with an optional Rock Remover that features a rotating scoop wheel that picks up non-floating debris from the transferring line and carries it to a discharge point. Its multiple functions and compact footprint make the Hydrolift Destoner machine essential to your processing line.

- Discharge rates from 25,000 to 50,000 pounds per hour
- Compact footprint and discharge height of up to 28 feet
- Specialized auger design nearly eliminates product damage and cuts while keeping flow consistent
- Optional rock remover automatically discharges debris from the bottom of the hopper
- Sanitary design with optional auger door allows for quick and thorough cleaning

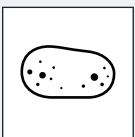

Potatoes

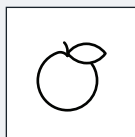

Apples

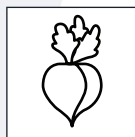

Beets

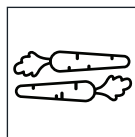

Carrots

Hydrolift Destoner

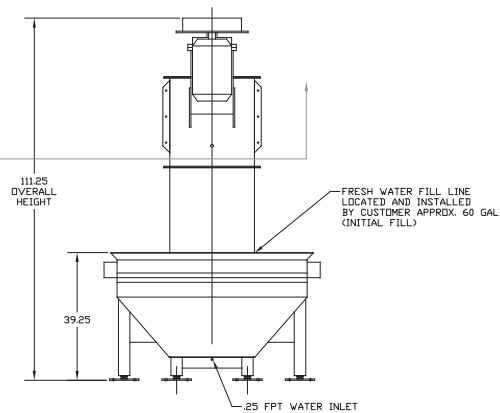
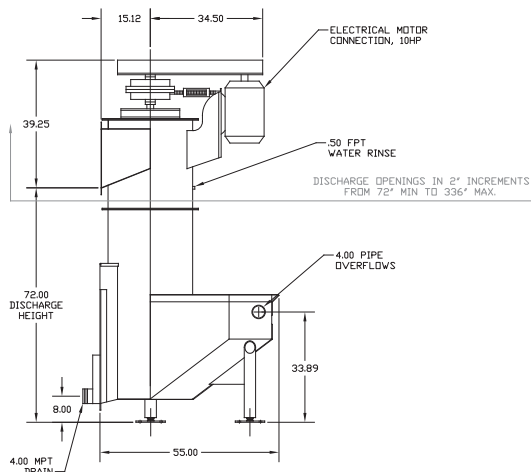
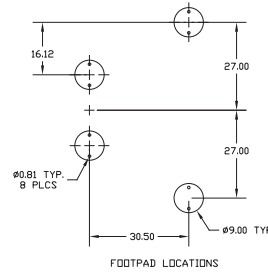
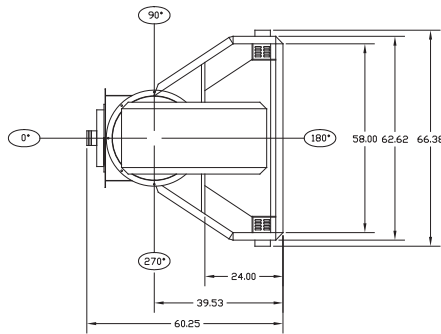

Specifications

Discharge Height: 72-336" (1.8-8.5 m)

Hourly Discharge Rates:

Series 2000: up to 25,000 lbs. (11,350 kg)

Series 2100: up to 50,000 lbs. (22,700 kg)

Electrical: 230-460 VAC, 60 Hz,
3 Phase (other voltages available)

Motor: Series 2000: 2 HP
Series 2100: 10 HP

Weight (varying by discharge height):

Series 2000: 1500 lbs. (680 kg)

Series 2100: 2200 lbs. (998 kg)

Features

- 304 stainless steel construction
- Five-sided corner hopper ensures consistent product flow
- Various, application-specific discharge chute angles
- Water-lubricated bearing lower bearing

Options

- Series 2000 and 2100 models available
- Continuous and Ground and Polished Welds
- Optional Tank and Auger Cleanout Doors
- Rock Remover

E 1.23v6

Contact Us

Vanmark is proud to provide top quality equipment, exceptional service and peace of mind worldwide for the potato and produce processing industries. Contact us for more information and to custom-fit the Hydrolift Destoner for your specific application.



To feed our growing world - Together

Phone: +1 740-201-0004

Email: sales@vanmark.com

vanmark.com